

## USER MANUAL 用户手册

USER MANUAL 用户手册 .....	1
1. INTRODUCTION FOR USER MANUAL 用户手册介绍 .....	2
1.1 DISCLAIMER 免责声明 .....	2
1.2 LIMITATION OF LIABILITY 责任范围 .....	2
2. SAFETY PRECAUTIONS 安全措施 .....	2
2.1 WARNING 警告 .....	2
2.2 GENERAL SAFETY 通用安全 .....	2
2.3 HANDLING SAFETY 操作安全 .....	3
3. UNLOAD/TRANSPROTATION/STORAGE 卸货、运输和存储 .....	4
3.1 MAKERS ON OUTER PACKAGING 包装标示说明 .....	5
3.2 UNLOADING WARNING 卸货注意事项 .....	6
3.3 SECONDARY TRANSPORT AND WARNING 二次运输及注意事项 .....	7
3.4 STORAGE 存储 .....	8
4. UNPACKING INTRODUCTION 拆包说明 .....	9
4.1 UNPACKING SAFETY 拆包安全: .....	9
4.2 UNPACKING STEP 拆包步骤: .....	9
5. SITE SELECTION 场地选择 .....	11
6. TILT ANGLE 倾角选择 .....	13
7. INSTALLATION 安装 .....	13
7.1 INSTALLATION SAFETY 安装安全 .....	13
7.2 INSTALLATION METHOD 安装方法 .....	15
7.2.1 MECHINICAL INSTALLATION AND WARRING 机械安装及注意事项 .....	15
7.2.2 GROUNDING 接地 .....	25
7.2.3 ELECTRICAL INSTALLATION 电气安装 .....	26
8. INVERTER SELECTION AND COMPATIBILITY 逆变器的选择及其兼容性 .....	29
9. MODULE MAINTENANCE FOR PV MODULE PV 组件的维护 .....	30
9.1 PANEL VISION INSPECTION AND REPLACEMENT 组件外观检查和替换 .....	30
9.2 CONNECTOR AND CABLE INSPECTION 连接器和线缆检查 .....	31
9.3 CLEANNING 清洗 .....	31
9.3.1 REQUIREMENTS FOR WATER QUALITY 水质要求 .....	33
9.3.2 MODULE INSPECTION AFTER CLEANING 清洗后组件检查 .....	33
9.3.3 TROUBLESHOOTING 故障排查 .....	34
10. REPORTING TECHNICAL ISSUES or CLAIMS 技术问题或索赔 .....	34

## 1. INTRODUCTION FOR USER MANUAL 用户手册介绍

This Manual applies to the installation, maintenance and use of the Duomax series solar modules manufactured by TrinaSolar Ltd. (hereinafter referred to as “Trina Solar”). Failure to follow these safety instructions could result in personal injury or property damage.

本手册适用于 TrinaSolar Ltd. (以下简称 天合光能)生产的双玻系列太阳能组件的安装、维护和使用。如果不遵守这些安全指南，将可能导致人员伤亡或财产损失。

Installation and operation of solar modules require specialized skills, and only professional personnel can engage in the work. Please read the “Safety and Installation Instructions” carefully before using and operating the modules. The installer must inform the end customer (or consumer) of the above matters accordingly.

安装和操作太阳能组件需要专业的技能，只有专业人员才可以从事该项工作。请在使用和操作组件之前仔细阅读安全和安装说明。安装商必须相应地把上述事项告知终端客户（或消费者）。

The term “Module” or “PV Module” in this Manual refers to one or more Duomax series solar modules. Please keep this Manual for future reference.

本手册中的“组件”或“PV 组件”指的是一个或多个双玻系列太阳能组件。请保留此说明书以供将来参考。

### 1.1 DISCLAIMER 免责声明

Trina Solar reserves the rights to change this User Manual without prior notice. Failure of the customer to follow the requirements outlined in this Manual during the installation of the module will result in the invalidity of product's limited warranty.

天合光能保留在没有预先通知的情况下变更本安装手册的权利。客户在安装组件过程中未按照本手册中所列出的要求操作，会导致提供给客户的产品有限质保失效。

### 1.2 LIMITATION OF LIABILITY 责任范围

Trina Solar is not responsible for any form of damage, including but not limited to module operation and system installation error, and personnel injury, hurt, and property loss resulted from failure to follow the instructions in this Manual.

天合光能不为任何形式的伤害负责，包括但不限于组件操作、系统安装失误以及未按照本手册的指示产生的身体伤害、受伤和财产损失负责。

## 2. SAFETY PRECAUTIONS 安全措施

### 2.1 WARNING 警告

Before installing, wiring, operating, or maintaining Trina modules, you should read and understand all safety precautions. Direct current (DC) is generated when the battery surface of the module is exposed to direct sunlight or other light sources, and direct contact with the live parts of the module, such as terminals, may result in death of personnel whether connected to the module or not .

对组件进行安装、接线、操作或维护前，应阅读并理解所有安全细则。当组件电池面直接暴露在阳光或其他光源下时，会产生直流电(DC)，无论是否连接组件，直接接触组件的带电部分，例如接线端子等，将可能导致人员伤亡。

### 2.2 GENERAL SAFETY 通用安全

- All installation work must comply with the local codes and the relevant international electrical standards.

所有的安装工作必须完全遵守当地法规和相应的国际电气标准。

- Trina recommends that PV module installation is conducted by personnel with experience in PV system installation. Operation by personnel who are not familiar with the relevant safety procedures will be very dangerous.

建议由具备光伏系统安装经验的人员进行安装。如果由不熟悉相应安全程序的人员操作将会非常危险。

- Do NOT allow unauthorized persons to access the installation area or module storage area.

不允许未经授权的人员接近安装区域或者组件仓储区域。

- Do NOT install modules with damaged glass

请不要安装玻璃已损坏的组件。

- Do NOT disassemble or move any part of the module.

不要拆解或移动组件中的任何部分。

- Do NOT artificially focus the light on the module.

不要人为在组件上聚光。

- Do NOT connect or disconnect the module when it is energized or connected with the external power supply

当组件有电流或外部电流出现时，不得连接或断开组件

### 2.3 HANDLING SAFETY 操作安全

- Do NOT stand, walk on or step on the module directly.

禁止直接在包装或组件上站立、踩踏、行走或跳跃。



- Do NOT damage or scratch the front or backside surfaces of the module.

请不要损坏或敲打组件的玻璃和背板面。

- Do NOT scratch the output cable or bend it with force. The insulation of output cable can break and may result in electricity leakage or shock.

请不要拉扯、划伤或用力弯折输出线缆，否则线缆的绝缘部分会被损坏导致电流泄露或触电。

- Do NOT use water to extinguish fires of an electrical origin.

请不要在电源未断开的情况下，使用水来灭火。

- Do NOT install or handle modules when they are wet or during periods of high wind. At the installation site, take care to keep modules and in particular their electrical contacts, clean and dry before installation. If connector cables are left in damp conditions then the contacts may corrode. Any module with corroded contacts should not be used.

请不要在潮湿或者大风期间安装或处理组件。在安装现场，请保持组件电器元件

的清洁与干燥。如果线缆插头在潮湿条件下互相接触，会被腐蚀。任何被腐蚀的组件都不能被使用。

- Please do NOT loosen or unscrew the PV module bolts, which may lead to the module loading drop or even fall down.

请不要松动或拧下光伏组件的螺丝，有可能导致组件载荷下降，甚至掉落

- Do NOT drop PV modules or allow objects to fall down on the PV modules.

请不要让物体直击组件或物体直接掉落在组件上。

- Do NOT touch the terminal box or the ends of the output cables (connectors) with bare hands under sunlight, regardless of whether the PV module is connected to or disconnected from the system.

在阳光下，请不要在没有任何保护的情况下用手直接触摸组件的接线盒、连接器、线缆等带电体，无论光伏组件是否与系统连接。

### 3. UNLOAD/TRANSPROTATION/STORAGE 卸货、运输和存储

#### Precautions and general safety rules:

预防措施和通用安全细则：

- The modules should be stored in the original package before installation. Protect the package from damage. Unpack the modules as per the recommended unpacking procedures. The whole process of unpacking, transport and storing should be handled with care;

组件在安装前应存储在原包装箱内，请保护好包装不要使其受损。按照建议的拆包步骤打开组件包装。打开、运输和存储过程需小心操作；

- Do NOT stand, climb, walk or jump on unpacked pallets of modules;

禁止在未拆包的包装箱上及组件上站立、攀爬、行走或跳跃；

- Before installation, ensure that all modules and electrical contacts are clean and dry;

安装前，确保所有组件和电气接触都是干净和干燥的；

- If the modules are required to be stored temporarily, they should be stored under dry and ventilated conditions;

如果需要暂时存放组件，则应将组件存储在干燥通风的环境中；

- Unpacking must be carried out by two or more persons at the same time. It is forbidden to pull the wires or junction boxes of the modules to carry the modules. Handling the modules requires two or more people with non-slip gloves; do NOT handle the modules in an overhead way or stack the modules;

拆包时，必须由2个或2个以上人员同时操作，禁止拉扯组件的导线或接线盒来搬运组件，搬运组件时应由2个人以上带防滑手套同时手持组件搬运；禁止头顶组件搬运；禁止堆叠组件；

- Do NOT put the modules in a place that is not supported or fixed;

禁止将组件置于无可靠支撑或未固定的环境下；

- Do NOT allow the modules to come in contact with sharp-pointed objectives to prevent them from scratches, avoiding a direct impact on the safety of modules.

禁止组件与尖锐物接触，划痕，以免直接影响组件的安全性；

### 3.1 MAKERS ON OUTER PACKAGING 包装标示说明

<p>3.1.1 Do NOT discard the modules at will; special recycling is required 禁止组件随意丢弃，需要专门回收</p>  <p>EU-28 WEEE COMPLIANT</p>	<p>3.1.2 Modules shall be kept dry, not exposing to the rain or moisture 禁止组件淋雨或者受潮</p> 
<p>3.1.3 Modules in carton are fragile, which shall be handled with care 纸箱中的组件为易碎物品，搬运时应小 心轻放</p> 	<p>3.1.4 The packaging shall be transported upright 包装在运输时应竖直向上</p> 
<p>3.1.5 Do NOT step on the package and module 禁止在包装箱和组件上面踩踏</p> 	<p>3.1.6 The carton can be recycled 纸箱可循环再利用</p> 
<p>3.1.7 Modules shall be stacked as required, not exceeding the maximum number of layers printed on the outer packaging. ( n = 2 means no more than two layers and n = 3 means no more than three layers) 堆叠组件时请勿超过外包装箱上印刷标 志的最高层数限制，（n=2 时，最多堆 码 2 层； n =3 时，最多堆码 3 层）</p> 	<p>3.1.8 One module shall be handled by two persons together 一块组件需由 2 个人同时搬运</p> 

### 3.2 UNLOADING WARNING 卸货注意事项

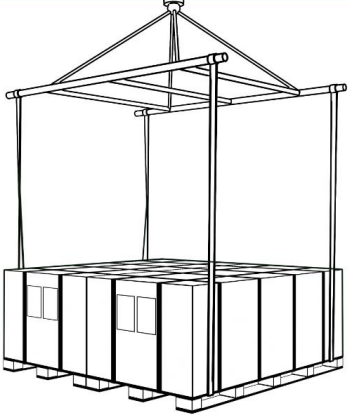
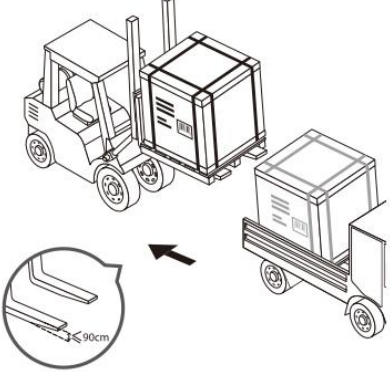
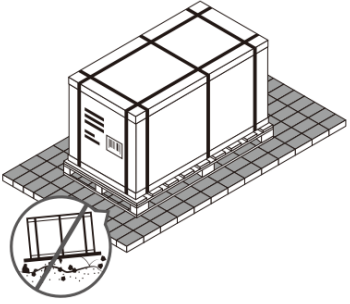
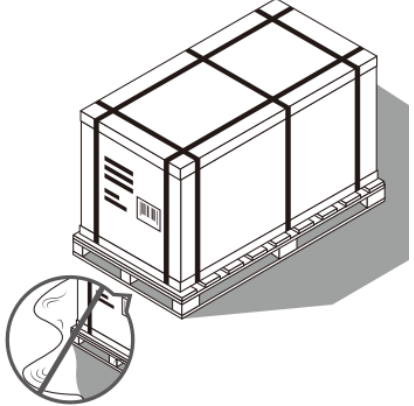
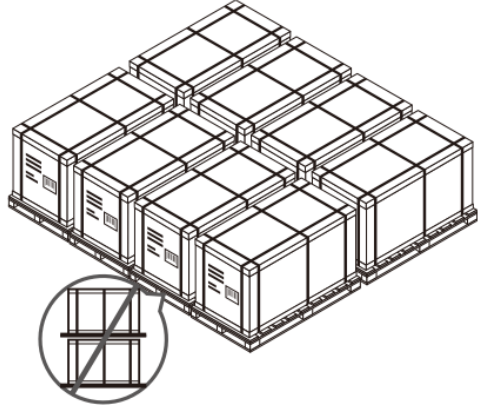
<p><b>3.2.1</b> Use the correct (as picture) lifting fixture to handle, no more than 2 pallets for one time lifting. Before lifting, please confirm whether the tray and the carton are damaged and the hoisting rope is firm and solid or not. Before lifting touchdown, two persons shall support at two sides of the righting carton gently to put it on a relatively flat place. 使用合理的吊装治具，吊装一次性最多允许 2 托组件。吊装前应确认托盘和纸箱是否有破损及吊装的绳索是否结实、牢固。吊装快着地时，两人一人一边扶正纸箱轻轻放在项目地相对平坦的位置上。</p> 	<p><b>3.2.2</b> If the condition permits, use a fork lift to remove the module from the truck 请使用叉车将组件从货车上卸下来</p>  <p><b>Put the module on the level ground</b> 将组件放置于水平地面上。</p> 
<p><b>3.2.3</b> Store the module in a dry and ventilated place 将组件放置在通风干燥处</p> 	<p><b>3.2.4</b> No stacking the modules at the project site. 禁止在项目地将组件堆码。</p> 
<p><b>3.2.5</b> Cover the module with waterproof cloth to prevent it from moisture 使用遮雨布盖住组件，防止组件受潮</p>	

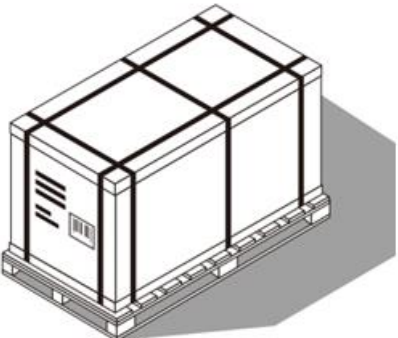
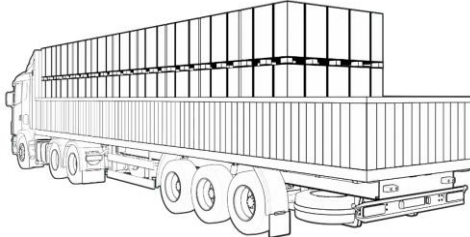
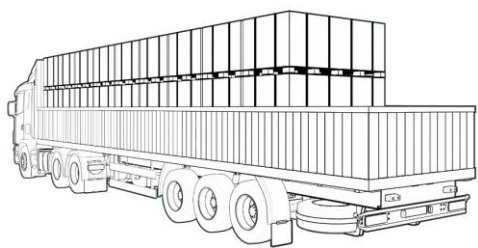
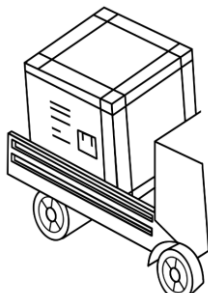

### 3.3 SECONDARY TRANSPORT AND WARNING 二次运输及注意事项

<p><b>3.3.1</b> Do NOT remove the original packaging if the modules require long-distance transport or long-term storage. 如果组件需要长途运输或长期存储，请不要拆除原包装。</p> 	<p><b>3.3.2</b> The finished package can be transported by land, sea or air. During transport, make sure that the package is fixed to the shipping platform without moving. 包装的成品可以通过陆运、海运、或空运进行运输。在运输过程中：请将包装箱固定在运输平台上，确保包装不会翻滚。（以陆运为例）</p> 
<p><b>3.3.3</b> Transport: stacking no more than two layers by truck normally; 运输：正常卡车运输时，最多 2 层叠加后运输；</p> 	<p><b>3.3.4</b> One layer stacking for transport is only allowed at project site 项目现场托运，只允许 1 层运输。</p> 
<p><b>3.3.5</b> No transport or handling by pedi-cab as below; 禁止三轮车转运；</p>	<p><b>3.3.6</b> No handling the module with rope 禁止用绳子背组件</p>

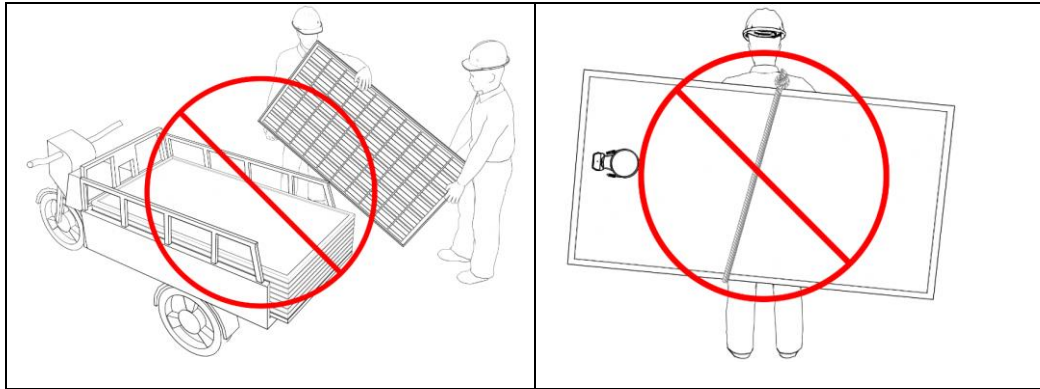

**3.3.7**  
 No carrying the modules on the back of one person;  
 禁止单人背组件;



### 3.4 STORAGE 存储

- Do NOT expose the modules to rain or moisture. Store the finished product in a ventilated, waterproof and dry place.
- 禁止淋雨或者受潮，请将包装的成品置于通风、防雨和干燥的地方。
- Do NOT remove the original packaging if the module requires long-distance transport or long-term storage.
- 如果组件需要长途运输或长期存储，请不要拆除它。

**3.4.1**  
 Storage in project site warehouse (moisture < 85%, temperature in the range from -20°C to + 50 °C): 60-cell module and 72-cell module to be stacked separately in two groups  
 项目地仓库存储（湿度 < 85%；温度：-20°C ~+50°C）：60 片双玻组件与 72 片双玻组件静态堆码堆放 2 托

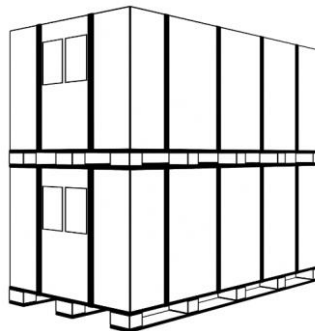

**3.4.2**  
 Normal warehouse storage (moisture < 85% and temperature in the range from -20°C to + 50 °C): 60-cell module to be stacked no more than three layers and 72-cell module to be stacked no more than two layers (take 72-cell module for



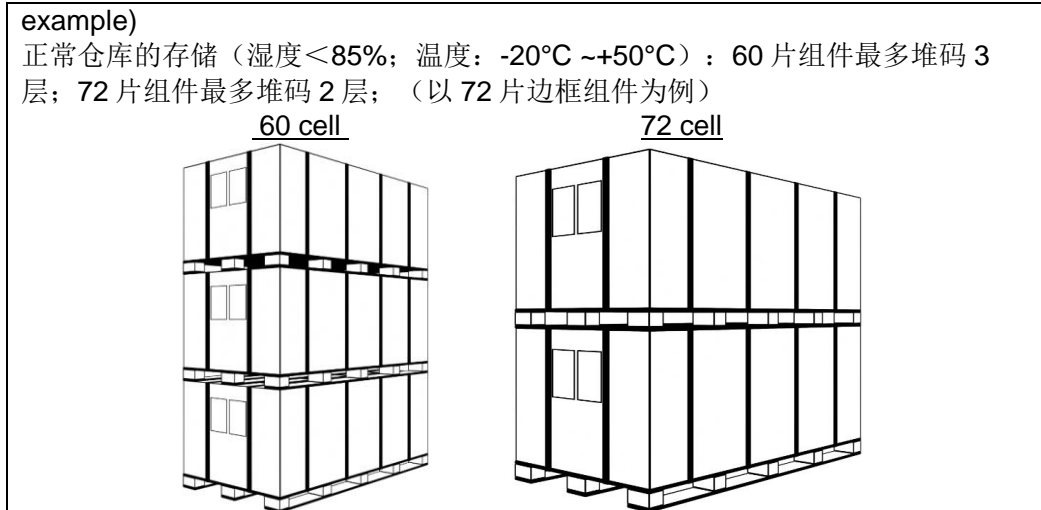

#### 4. UNPACKING INTRODUCTION 拆包说明

##### 4.1 UNPACKING SAFETY 拆包安全：

- As for outdoors unpacking, it is prohibited to operate in rainy conditions. Because the carton will become soft and damaged after it gets wet in the rain. The PV modules (hereinafter referred to as "modules") inside the pallet will release, which may cause damage or injury to personnel.

在户外拆箱时，禁止在下雨的条件下作业。因为纸箱淋雨后会变软散开，里面的光伏组件（下文简称“组件”）会脱出造成损坏或者砸伤人员。

- If there is wind at site, it is necessary to pay special attention to safety; especially in high wind conditions, it is NOT recommended to transport the modules, and the unpacked modules shall be fixed properly.

如果现场有风，需要特别注意安全，尤其是大风的情况下，建议不要搬运组件，并且妥善固定好已拆开包装的组件。

- The work surface is required to be level to ensure that the package can be placed stably, avoiding dumping.

作业地面需要保证包装箱能够水平稳定的放置，避免倾倒。

- Wear protective gloves during unpacking to avoid hand injury and fingerprints on the glass surface.

拆箱过程中请佩戴保护手套，避免伤手和在玻璃面留下指印。

- Module information and unpacking instructions can be found on the outer package. Please read the instructions before unpacking.

外包装可查询组件信息和拆包作业指导，请在拆包前详细阅读拆包说明。

- Each module shall be handled by two persons. It is forbidden to pull the wires or junction boxes of the modules to carry the module. No pulling the long side to take out the module.

每块组件需要2个人抬，抬组件时，禁止拉扯接线盒；禁止抓住长边取出组件

##### 4.2 UNPACKING STEP 拆包步骤：

4.2.1 Before unpacking, please check the product name, serial number and related suggestions on the A4 paper.	4.2.2 Cut the packing belt at shorter and longer sides in vertical direction of the tray with blade or scissors,
---	--

Please read the unpacking instructions carefully and the customized unpacking method is no allowed.

拆包前，请核对外箱 A4 纸上的产品名、序列号及相关建议, 并请仔细阅读拆包指导书，禁止自定义式的拆包方式。

用刀片或剪刀剪断所有竖向打包带

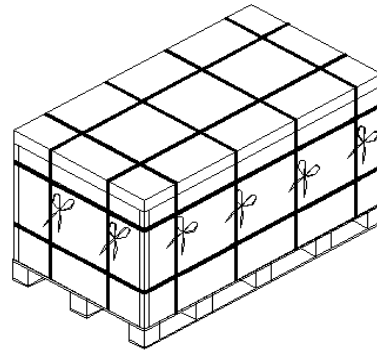

Unpacking instructions  
拆包指导书

A4 paper (product name, serial number, related suggestions, etc.)  
A4 纸 (产品名、序列号、相关建议等)

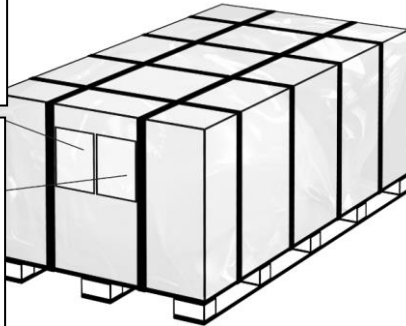

4.2.3  
Cover off the carton and take out two or three of the upper cover plate  
拿掉纸箱上盖，取出二或者三个上层盖板

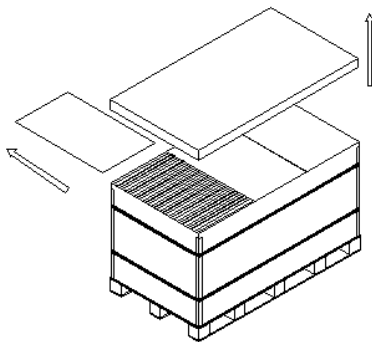

4.2.4  
Two people, on the both side of the box, lifting a module in the meantime. One hand holds the top corner of module, and the other hand holds the middle of the short side's . Taking out the module at the same time 两人站在箱子两侧，同时提住组件，一只手抓住组件的一角，另一只手抓住短边，同时将组件取出

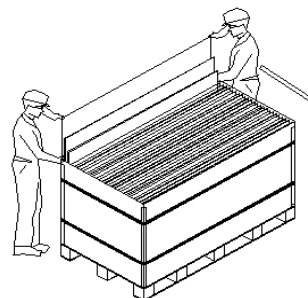

4.2.5  
When unpacking on a level surface, take out the module from one side of package to the other, and then carry it with two persons (Please refer to 3.1.8)  
若水平地面拆包，从包装一侧朝另一侧依次取出组件，然后两人搬运。请参考 3.1.8。  
若在非水平地面拆包，需要做好防倾斜措施，如下图红色部分。

4.2.6  
Do NOT lean the module on the mounting posts;  
禁止将组件斜靠在安装柱子上；

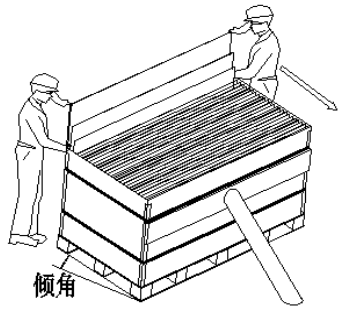
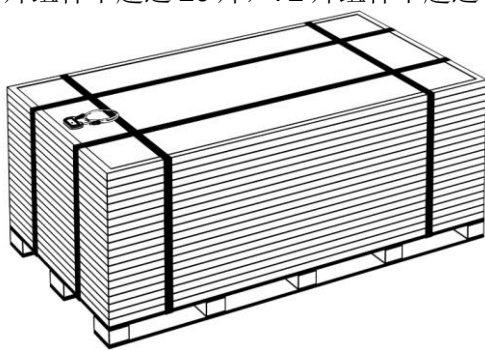

 <p style="text-align: center;">倾角</p>	
<p>4.2.7 If all the modules are NOT removed after unpacking and some of them are left in the package, the remaining modules shall be laid flat and repackaged to prevent from falling down. Must be placed by horizontal.</p> <p>The stacked number of modules: 60-cell modules to be stacked NOT more than 20 pieces, 72-cell modules NOT more than 16 pieces;</p> <p>如果拆包后没有将所有组件取出，有组件剩余在包装中的情况，则将剩余组件平放后重新打包，防止倾倒，需水平放置。</p> <p>组件叠放的数量：60片组件不超过20片，72片组件不超过16片。</p>	
	

## 5. SITE SELECTION 场地选择

- Solar modules are recommended to be installed at an optimized tilt angle to maximize the energy output. It is roughly equal to the latitude of the project site as a rule of thumb, facing toward the equator. Optimized system designs incorporate other local requirements.

建议通过优化的倾斜角安装太阳能组件以达到能量输出最大化。一般来说它大致等同于项目所在地的纬度，面向赤道方向。但在实际的设计中还是按照当地具体情况设计并找出最佳倾斜角。

- When installing solar modules on a roof always leave a safe working area between the edge of the roof and the external edge of the solar array

当在屋顶上安装太阳能组件时，要在屋顶边缘和太阳能阵列的外边缘之间留出安全的工作区域。

- In the case of residential installations on the ground, modules shall be installed following local regulations, e.g. using fence.

如果住宅设施在地面上，组件的安装应按照当地法规进行，例如安装中需要用到围栏

- Position the modules to minimize the chances of shading at any time of the day.

对组件进行定位以尽量减少其在一天中任何时间段遮光的可能性。

- Trina Solar recommends that the module should be installed at an ambient temperature of  $-40^{\circ}\text{C} \sim 50^{\circ}\text{C}$ . The module's limit working ambient temperature

range is from  $-40^{\circ}\text{C}$  to  $85^{\circ}\text{C}$ .

天合推荐组件安装在温度为 $-40^{\circ}\text{C}$ ~ $50^{\circ}\text{C}$ 的环境下，组件的极限工作环境温度 $-40^{\circ}\text{C}$ ~ $85^{\circ}\text{C}$ 。

- Try to install modules in a location where there is rare shading throughout the year

尽量将组件安装在一年中罕有遮阳的位置

- If you are planning to use the PV modules where the water damage (Humidity:  $> 85\text{RH}\%$ ) may be possible, please consult with Trina local technical support first to determine an appropriate installation method, or to determine whether the installation is possible.

如果您计划在可能出现水渍侵害的地方（湿度： $> 85\text{RH}\%$ ）使用光伏组件，请先向天合光能当地的技术支持团队咨询以确定合适的安装方法，或确定是否可以安装。

- If you are planning to use the PV modules in water or wet condition, please consult with Trina Solar local technical support first to determine an appropriate installation method or location.

- 如果需安装在水中或者潮湿环境请与天合光能当地技术支持联系合适的安装方式或者安装地点。

- If the module is installed in an area with frequent lightning and thunder, the module must be protected against lightning strikes. Refer to Trina Solar's declaration document for lightning protection. Please contact with local technical support or contact us from <http://www.trinasolar.com/>.

如果组件安装在有频繁雷电活动的地方是，必须要对组件进行防雷击保护，防雷请参考天合申明文件，获取该文件请联系当地技术支持或登录<http://www.trinasolar.com/>与我们联系：

- Make sure flammable gases are NOT generated near the installation site.

请勿安装在可燃气体附近。

- According to Intertek-conducted IEC 61701, salt mist corrosion testing of photovoltaic (PV), Trina Solar modules can be safely installed in corrosive salt areas within proximity of the ocean or sulfurous areas.

按照IEC 61701要求开展的光伏（PV）组件盐雾腐蚀试验结果表明，天合光能的太阳能组件可以安全地安装在近海或亚硫酸盐区域附近的腐蚀性盐碱地区。

- In locations that are 50m ~ 500mm from the ocean, stainless steel or aluminum materials must be used to contact the PV modules, and the installation position must be processed with anti-corrosion treatment; refer to the "Trina Solar Coastal Application White Paper" for detailed installation requirements. Please contact with local technical support or contact us from <http://www.trinasolar.com/>.

在离海边50m~500mm的地方，必须采用不锈钢或者铝材料来与光伏组件接触，并且对安装部位做好防锈蚀的处理，详细安装要求见天合沿海应用白皮书。获取该文件请联系当地技术支持或登录<http://www.trinasolar.com/>与我们联系

- According to IEC62716:2013 "Ammonia corrosion testing of photovoltaic (PV) modules" and DLG Fokus testing for ammonia resistance, Trina Solar modules can be safely installed in ammonia-heavy environments, such as farm houses.

IEC62716:2013“光伏（PV）组件的氨腐蚀试验”和DLG Fokus耐氨性试验的结

果表明，天合光能太阳能组件可以安全地安装在像农舍这样的氨气较重的环境中。

## 6. TILT ANGLE 倾角选择

- The tilt angle measurement of the PV module refers to measuring the angle between the module and the horizontal ground surface. For different projects there are different mounting angles. Trina Solar recommends that the mounting tilt angle should be NOT less than 10°, or in accordance with local regulations or follow the recommendations of experienced PV module installers.

光伏组件的倾角测量指组件与水平地面的角度。针对不同的项目有不同的安装倾角，天合推荐的组件安装夹角不小于10°，或依据当地法规指南或有经验的光伏组件安装商的建议。

- The tilt angle of the PV module is measured between the PV module and a horizontal ground surface.

通过测量PV组件和水平地面之间的夹角来得出PV组件的倾斜角测量值。

- In the Northern Hemisphere, the PV modules should typically face south, and in the Southern Hemisphere, the PV modules should typically face north.

在北半球安装，组件最好朝南，在南半球安装，组件最好朝北。

- A clearance of at least 115mm (4.5in) (recommended) is provided between modules and the surface of the wall or roof. If other mounting means are employed this may affect the UL Listing or the fire class ratings.

应在组件和墙面或屋顶表面之间留有至少115mm（4.5英寸）（建议）的间隙。如果采用其他安装方式，则有可能会影响UL认证或防火等级。

## 7. INSTALLATION 安装

Trina Solar Duomax series modules may be installed in the following conditions for more than 30 years. In addition to the required IEC certification, Trina Solar products have also been tested to verify resistance to ammonia fumes that may be present around barns sheltering cattle, as well as suitability for installation in humid (coastal) areas and areas of high sand storms.

天合光能双玻系列组件按照以下条件安装可以使用30年以上。除了所需的IEC认证外，天合光能产品还经过测试以验证其对牛棚附近可能存在的氨气的抵抗性，以及其是否适合安装在潮湿（沿海）区域和沙尘暴频发区域。

### 7.1 INSTALLATION SAFETY 安装安全

- Trina Solar Modules can be mounted in landscape or portrait orientation however the impact of dirt shading the solar cells can be minimized by orienting the product in landscape.

天合光能的太阳能组件可以横向或纵向安装，但是采用横向安装的方式可以使灰尘对太阳能电池板的遮光影响最小化。

- Always wear dry insulation protection equipment: insulated tools, head gear, insulated gloves, safety belt and safety shoes (with rubber soles).

请使用干燥的绝缘防护措施：如绝缘工具、安全帽、绝缘手套、安全带和安全鞋（橡胶底）。

- Do NOT wear metallic jewelry which can cause electric shock during installation.

安装时请不要佩戴金属饰物，以免戳穿组件，引起触电危险。

- Do NOT install modules under rain, snow or windy conditions.  
请勿在下雨、下雪或大风的情况下安装组件。
- Please keep the connector dry and clean during installation to avoid the risk of electric shock. It is recommended to install it immediately after unpacking.  
安装时请保持连接器干燥清洁，以免触电风险，建议开箱后立即安装。
- Due to the risk of electrical shock, do NOT perform any work if the terminals of PV module are wet. Please install immediately after you unpacking.  
如果PV组件的端子潮湿则不能进行任何工作，以免触电。请在开箱后立即安装。
- The application level of Trina Solar module is Class A, which can be used in systems operating at greater than 50 V DC or 240 W, where general contact access is anticipated;  
天合组件的应用等级为A类，可用于>直流50V 或240W以上的系统；
- Keep the PV module packed in the carton until installation.  
在安装之前，将PV组件保留在纸箱中。
- Please use an opaque material to completely cover the PV module surface during PV module installation and wiring.  
在PV组件安装和布线期间，请使用绝缘材料将PV组件表面完全覆盖住。
- Do NOT unplug the connector if the system circuit is connected to a load.  
如果系统电路与负载接通，请不要拔下连接插头。
- Do NOT stand on the module glass while installing. There is a risk of injury or electric shock if glass is broken.  
工作时不要站在玻璃上，以免玻璃破碎造成伤害或引发触电危险。
- Do NOT work alone (always work as a team of 2 or more people).  
不要单独工作（一直保持由2个或更多的人组成团队工作）
- Do NOT damage the back glass of PV modules when fastening the PV modules to a support with bolts.  
在通过螺栓将PV组件紧固到支架上时，不要损坏PV组件的背面玻璃
- Do NOT damage the surrounding PV modules or mounting structure when replacing a PV module.  
更换PV组件时，不要损坏周围的PV组件或安装结构
- Cables shall be located and secured so that they will not be exposed to direct sunlight after installation to prevent degradation of cables. Low drooping of cables from the terminal box must be avoided. Low hanging cables could cause various problems such as animal biting, electricity leakage in water, and fire.  
电缆应固定起来或绑好，这样在安装后不会暴露在阳光直射下，可以防止电缆老化。从接线盒下引出电缆可能会引起各种问题，例如积水处漏电和火灾。
- Modules with different color codes should not be installed in one block or the same rooftop.  
不同色系组件避免安装在同一阵列或屋顶中。

## 7.2 INSTALLATION METHOD 安装方法

### 7.2.1 MECHANICAL INSTALLATION AND WARNING 机械安装及注意事项

The connection of the module to the racking system can be created through the Gecko grip, with clamps, with frame, or an embedded system on the frame. The modules must be installed according to the following examples and recommendations. If a different installation method is desired, please contact Trina Solar customer service or technical support team for consultation. Improperly mounted modules may be damaged. If alternative mounting method is used and not approved by Trina, the modules will not continue to have a valid warranty.

组件和支架系统的连接可以使用挂钩、夹具、边框或者嵌入式系统来安装。安装组件必须依照下面示例和建议进行，如果安装方式与天合公示不同，请咨询天合当地技术支持或售后，并取得天合同意，否则会损坏组件并导致质保失效。

- Panels shall not be subjected to wind or snow loads exceeding the maximum permissible loads, and shall not be subjected to excessive forces due to the thermal expansion of the support structures.

组件不能承受超过最大许可载荷的暴风雪冲击，也不能承受因支撑结构的热膨胀而引起的过大的力。

- The module frame drain holes cannot be blocked in any situation during installation or use.

安装或使用过程中，排水孔在任何情况下都不能堵塞。

#### A. Mounting with Gecko Grip (Apply to Duomax series) 挂钩安装 (适用于双玻组件)

Modules can be attached through the Gecko grip on the back side of the module, by fixing the module to the support rails with bolts. The mounting details are shown in the following figures.

通过组件背面上的挂钩，使用螺栓把组件固定在支架上，安装细节如下图所示。

The module backside has 4 hooks, ideally placed to optimize the load handling capability, to secure the modules to supporting structure.

每个组件背面有4个挂钩，通过这些挂钩可以很好地将组件固定到支撑结构上以优化其负载承受能力。

- To maximize mounting longevity, Trina Solar strongly recommends the use of corrosion proof (stainless steel) attachment hardware.

为了最大限度地延长安装寿命，天合光能强烈建议使用抗腐蚀（不锈钢）固定件

- Secure the module in each mounting location with an M8 bolt (for 60 pcs) and M10 bolt (for 72 pcs) and a flat washer, spring washer and nut and tighten to a torque of 16~20 N.m (140-180 lbf.in.).

使用M8螺栓(60片使用)、M10螺栓(72片使用)、平垫圈、弹簧垫圈和螺母在每个固定位置固定组件，并拧紧至16~20 N.m (140-180 lbf.in.)的扭矩。

- All parts in contact with the hook should use flat stainless steel washers of minimum 1.8mm thickness with an outer diameter of 20-24mm (0.79-0.94in).

与挂钩接触的所有部位应采用最小厚度为1.8mm且外径为20-24mm (0.79-0.94英寸)的扁平不锈钢垫圈。

- The minimum distance between two modules is 25mm (1 in).

两个组件之间的最小间距为25mm (1英寸)

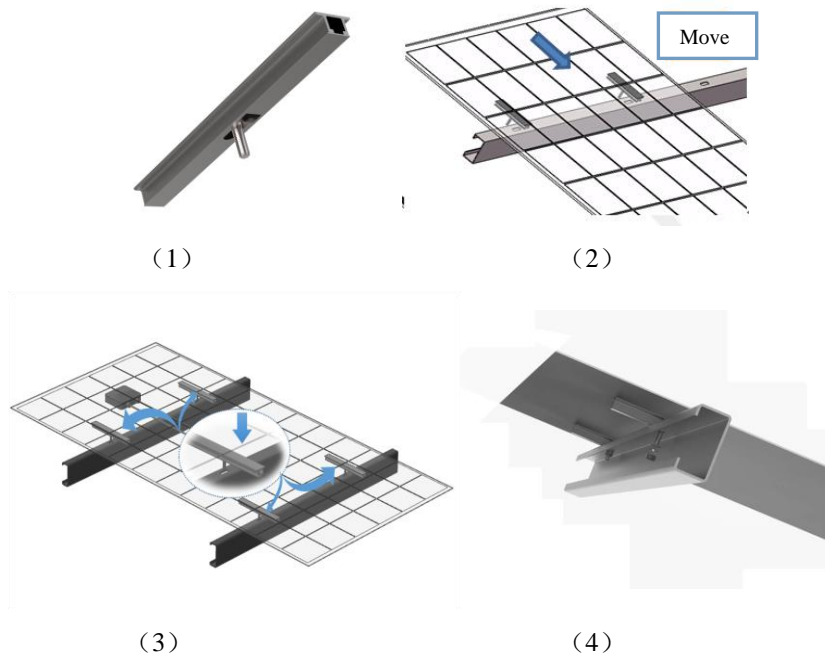

**Figure 1. PV module installed with Gecko Grip**

**图 1.使用挂钩安装的 PV 组件**

- (1) set the bolts into hook 把螺栓插入挂钩
- (2) lift the module over racking 组件抬起放在支架上
- (3) Insert the bolt into the hole 螺栓插入安装孔
- (4) Tighten the nut 拧紧螺母

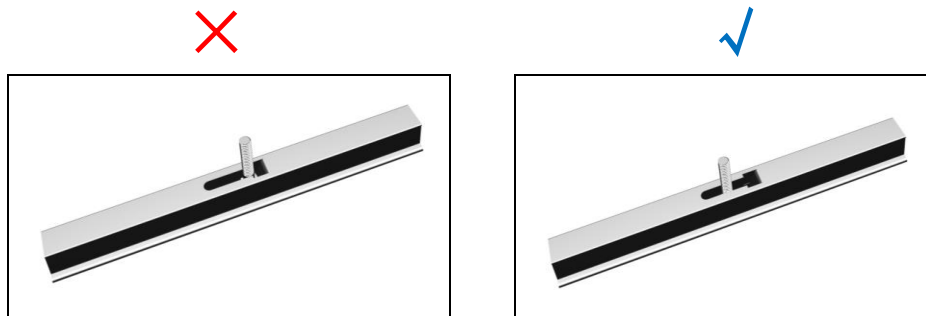

**\*NOTE: Don't fix the hex nuts on head of the insert place. (As shown above).**

**\*注意：不用把螺母滑到槽口边缘（如上图所示）**

**\*NOTE: Rack installation of connecting surface must smooth (As shown below).**

**\*注意：支架连接面需要保持平滑**

**\*NOTE: For PV module landscape installation, the supporting rails need change as shown in below;(add two rails)**

**\*注意：组件横装时，支撑梁需要调整如下图（增加两根梁）**

**For 60 cell module**



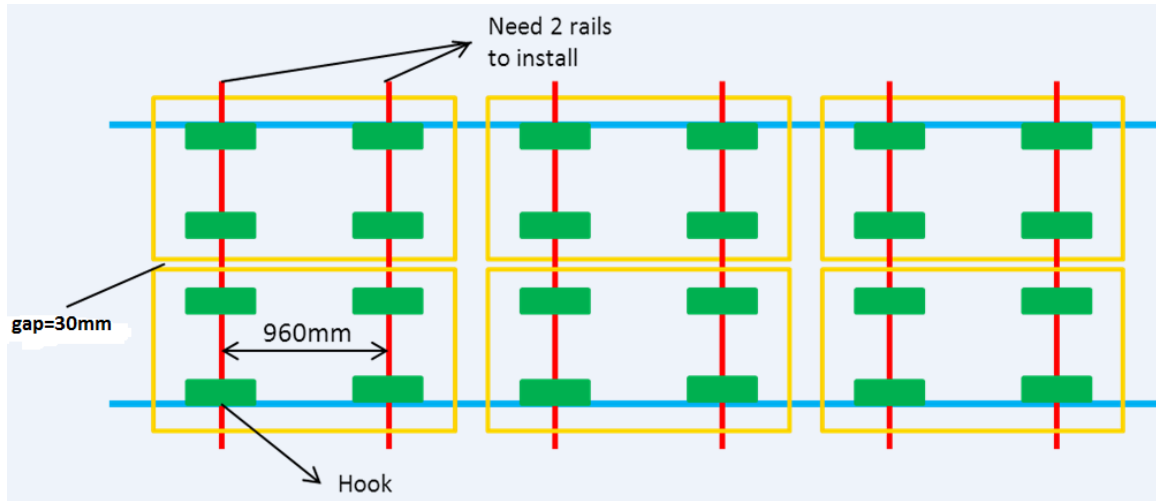

For 72 cell module

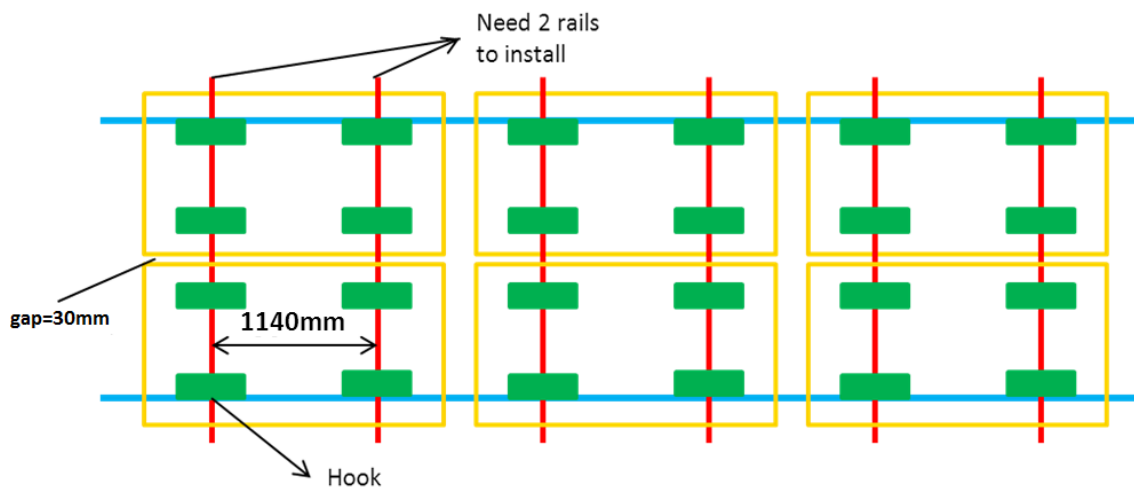

**B. Mounting with frame(Applied to Duomax twin , certificated in Sep.2017)**  
**边框安装 (适用双面组件,2017年9月份完成认证)**

- To maximize mounting longevity, Trina Solar strongly recommends the use of corrosion proof (stainless steel) attachment hardware.

为最大程度的延长支架寿命，天合光能建议使用防腐蚀（不锈钢）固件。

- Secure the module in the four symmetrical location of the frame with an M8 bolt (60 pcs) and M10 bolt(72 pcs) and a flat washer, spring washer and nut as shown in Figure 1 and tighten to a torque of 16~20 N.m(140-180lbf.in.)

- 使用M8螺栓、平垫圈、弹簧垫圈和螺母在边框的四个对称位置固定组件，并拧紧至16~20 N.m（140-180lbf.in）的扭矩

- All parts in contact with the hook should use flat stainless steel washers of minimum 1.8mm thickness with an outer diameter of 20-24mm (0.79-0.94in).

所有与边框接触的零部件都应该使用直径20-24毫米最小厚度1.8毫米的不锈钢平

垫圈

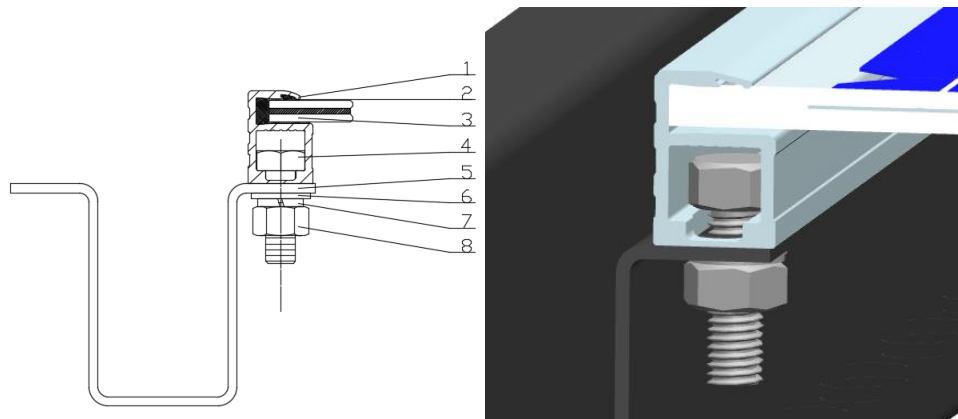

Figure 2 mount with frame

图 2 边框安装组件图示

- |                      |                        |
|----------------------|------------------------|
| 1.aluminum frame 铝边框 | 2.sealant 密封胶          |
| 3.module 组件          | 4. M8 hex bolt M8 六角螺栓 |
| 5 rail 几字横梁          | 6.flat washer 平垫片      |
| 7.spring washer 弹垫片  | 8.hex nut 六角螺母         |

**Step 1 步骤1: put the bolt in 装入螺栓**

Put the bolt in the frame mounting slot  
将螺丝依次放入边框安装滑槽内

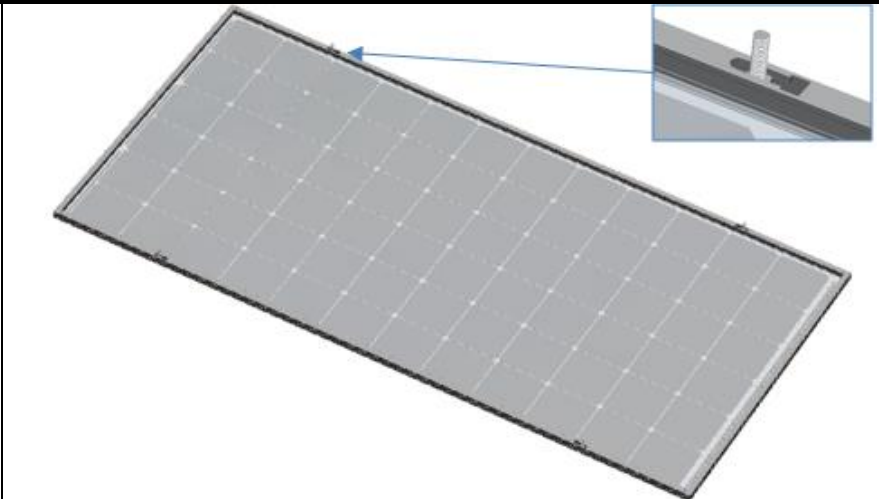

**Step 2 步骤2: connect to the rail 与支架连接**

<p>1. Lift the module ,fit the screw into the upper installation hole of the rail(J-box face upwards) 抬起组件，将边框内螺丝对入支架最上方两处安装孔。(组件安装接线盒一端朝上。)</p> <p>2. Fit the screw into the lower installation hole 依次对入下方安装孔</p>	
---	--

**Step 3步骤 3: move the module to position 推动组件至安装位置**

<p>Move the module upwards ,make sure the 2 bottom screws are not in slot opening 向上推动组件，确保组件下端两颗螺丝不处于滑槽口位置。</p>	
--	--

**Step 4步骤4: tighten the nut 紧固螺丝**

<p>Put in the flat washer ,spring washer and nut ,tighten to a torque of 16~20 N.m 依次放入平垫片，弹垫，螺母，用工具旋紧螺母，完成4处孔位的安装。 (16N·m~20N·m)</p>	
---	--

**Note :do not place the screw on the slot opening and fasten**  
**提醒: 勿将螺丝放置于滑槽口位置紧固。**

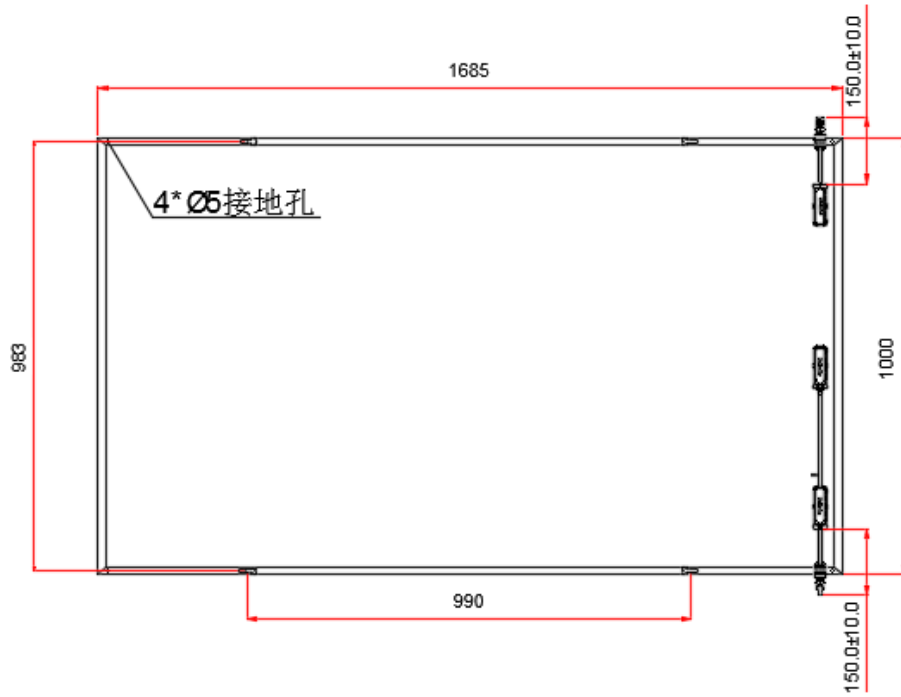

60 cell drawing

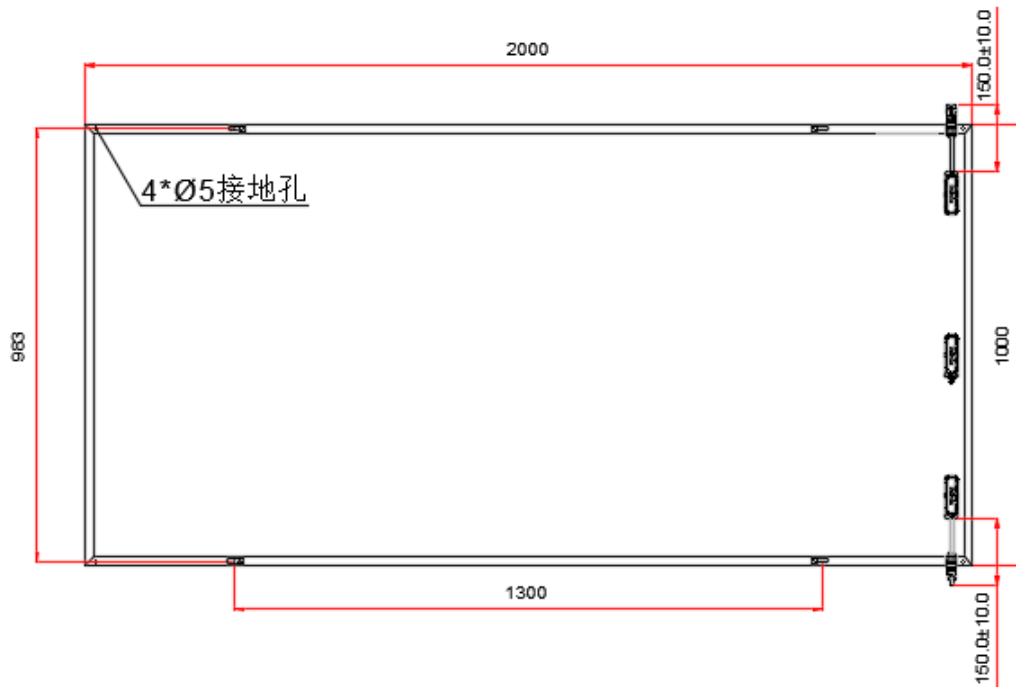

72 cell drawing

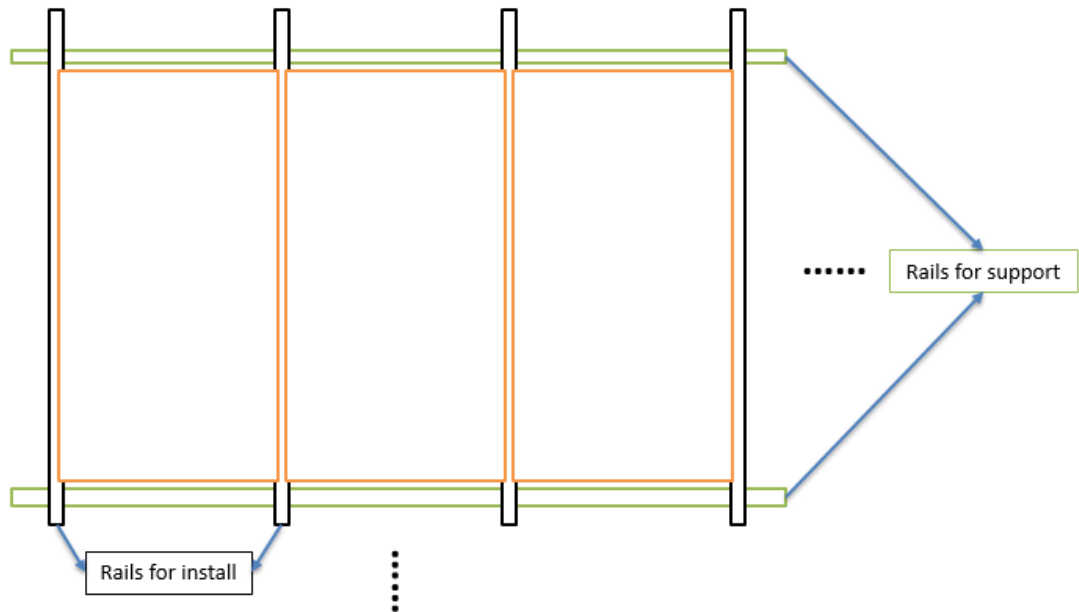

Figure 3 module drawing and Install sketch

图 3: 组件总装图和安装效果示意

### C. Mounting with Clamps (Apply to duomax and Dumax twin) 夹具安装(适用于双玻和双面组件)

- Trina Solar has tested its modules with a number of clamps from different manufacturers and recommends the use of clamps which have an EPDM or similar insulating washer, mounting bolt of at least M6.

天合光能在用多家制造商的不同夹具测试过其组件后，建议使用具有EPDM或类似的绝缘垫圈且至少可以固定M6螺栓的夹具。

- Use at minimum 4 clamps to attach modules to the mounting rails.  
使用至少4个夹具将组件固定在安装导轨上。
- Be sure to avoid shadowing effects from the module clamps.  
请务必避免组件夹具的遮光效应。
- When choosing this type of clamp-mounting method, use at least four clamps on each module, the 4 clamps should be attached on each long sides of the module. Depending on local wind and snow loads, additional clamps may be required to ensure that modules can bear the load.

当选择这种类型的夹具安装方法时，每个组件上至少需要使用四个夹具。在组件的每个长边上各安装两个夹具。视当地的风雪气象情况确定是否需要额外的夹具以确保组件能承受负载。

- Applied torque should refer to mechanical design standard according to the bolt customer is using, ex: M8 ---- 16-20N.m(140-180lbf.in)

施加的扭矩应按照客户所用螺栓的机械设计标准来定，例如：M8 ---- 16-20N.m (140-180lbf.in)

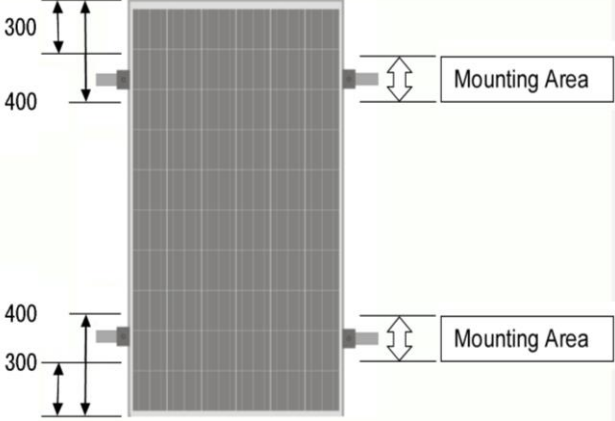
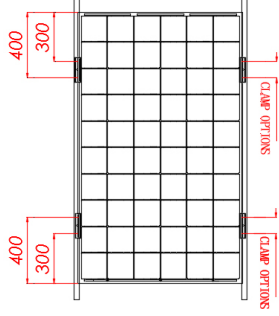
Mechanical Load Pressure 载荷	Length Of The Clamp 压块长度	Mounting Direction (Applied to 60 pcs Duomax) 安装图 (适用60片双玻)
+5400 Pa /-2400 Pa	150mm	 <p>*NOTE: The above-described distance is from the module edge to the middle of the clamp.            注意：标注距离为从组件边缘到压块中心            *NOTE: Need two support rails below the PV module to make sure the Mechanical load.            注意：需要组件背面两根梁支撑以满足所列载荷</p>
Mechanical Load Pressure 载荷	Length Of The Clamp 压块长度	Mounting Direction (Applied to 60 pcs Duomax twin) 安装图 (适用60片双面组件)
+2400 Pa /-2400 Pa	150mm	 <p>*Note: The above-described distance is from the module edge to the middle of the clamp.            注意：标注距离为从组件边缘到压块中心            *Note: certificated at 2017.09            备注：此种方式在 2017 年 9 月完成认证</p>
Mechanical Load Pressure 载荷	Length Of The Clamp 压块长度	Mounting Direction (Applied to 72 pcs Duomax) 安装图 (适用72片双玻组件)

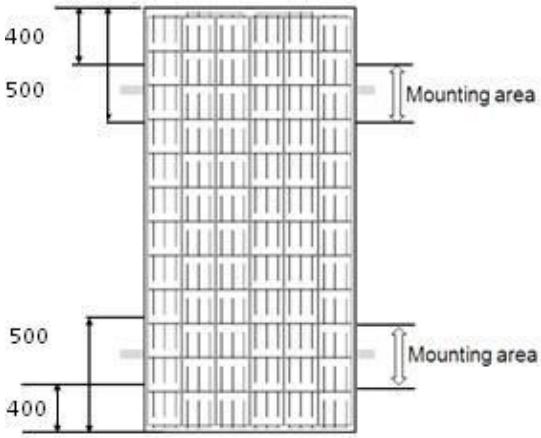
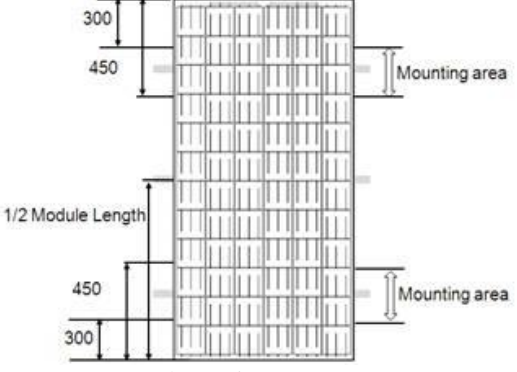
<p><b>+2400 Pa /-2400 Pa</b></p>	<p><b>150mm</b></p>	 <p>*NOTE: The above-described distance is from the module edge to the middle of the clamp. 注意：标注距离为从组件边缘到压块中心</p>
<p><b>+5400 Pa /-2400 Pa</b></p>	<p><b>150mm</b></p>	 <p>*NOTE: +5400 Pa when using 3 row connectors to support the module, the distance is from the module edge to the middle of the clamp. *NOTE: Need three support rails below the PV module to make sure the mechanical load. 注意：满足 5400Pa 需要 3 根横梁支撑，标注距离为从组件边缘到压块中心</p>
<p><b>Mechanical Load Pressure 载荷</b></p>	<p><b>Length Of The Clamp 压块长度</b></p>	<p><b>Mounting Direction</b> (Applied to 72 pcs Duomax twin) 安装图（适用 72 片双面组件）</p>

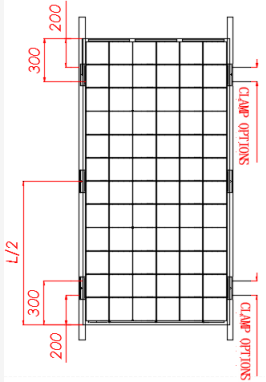
<p><b>+2400 Pa /- 2400 Pa</b></p>	<p><b>150mm</b></p>	 <p><b>**Note: The above-described distance is from the module edge to the middle of the clamp.</b>  <b>注意：标注距离为从组件边缘到压块中心</b></p> <p><b>*Note: certificated at 2017.09</b>  <b>备注：此种方式在 2017 年 9 月完成认证</b></p>
-----------------------------------	---------------------	---

The modules depicted are mounted on continuous rails that extend beneath the modules. If modules are mounted without continuous rails below them, the maximum allowable loading will be reduced and is subject to review by Trina.

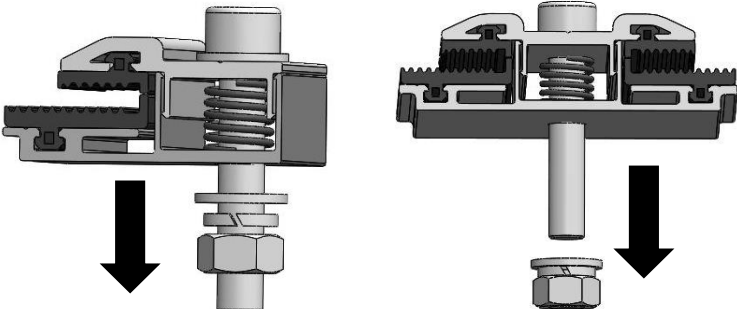
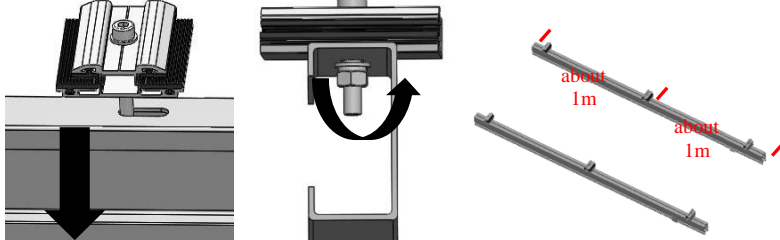
<b>STEP 1: Remove the connector parts 取下连接件</b>	
<p>Remove the bottom connector parts. 取下连接件</p>	
<b>STEP 2: Install the clamp 装上压块</b>	
<p>Put the clamp bolts into the installation holes, and then tighten the nuts. keep the distance between two clamps can install the PV modules. about 1m between each clamp, the width of double glass is 992mm          将螺栓对入安装孔，拧紧螺母；保持压块间距离可装入组件（组件宽 992mm，预留大约 1m）</p>	



### STEP 3: Install the PV modules 插入组件

Insert the PV module into the clamp, and make sure the module edge touch to the EPDM closely and then tighten the nut with uniform torque values using a qualified torque wrench to ensure the module is firmly secured.  
将组件插入压块，确保组件接触到 EPDM，拧紧螺母保证组件安装牢固。

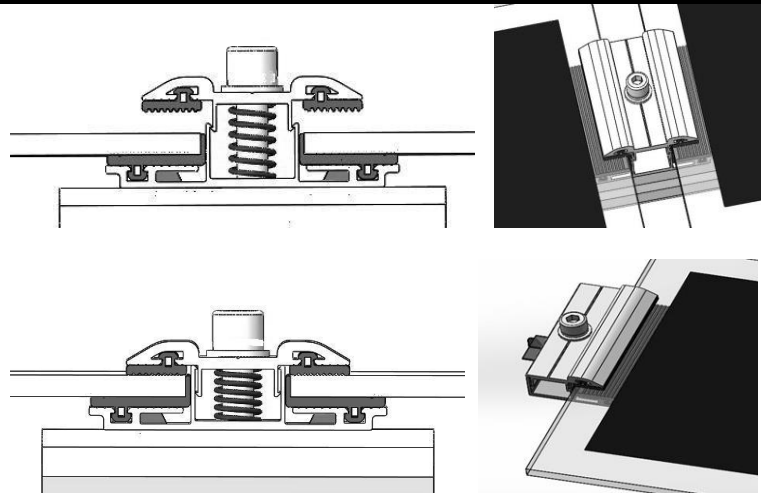

#### 7.2.2 GROUNDING 接地 (Apply to Duomax twin 适用双面组件)

- All module frames and mounting racks must be properly grounded in accordance with appropriate respective National Electrical Code.

所有组件边框和安装架必须按照相应的《国家电气规程》正确接地。

- Proper grounding is achieved by bonding the module frame(s) and all metallic structural members together continuously using a suitable grounding conductor. The grounding conductor or strap may be copper, copper alloy, or any other material acceptable for use as an electrical conductor per respective National Electrical Codes. The grounding conductor must then make a connection to earth using a suitable earth ground electrode.

通过使用合适的接地导体将组件边框和所有金属结构件连续连接在一起以实现正确接地。接地导体或接地线可以是铜、铜合金或任何其他符合相应的《国家电气规程》要求的用作电导体的材料。接地导体必须通过合适的接地电极连接到大地。

- Trina Solar modules can be installed with the use of third party listed grounding devices for grounding the metallic frames of PV modules. The devices have to be installed in accordance with the grounding device manufacturer's specified instructions.

天合光能的太阳能组件可以使用第三方列出的接地装置对PV组件的金属边框进行接地安装。设备必须按照接地设备制造商的指定说明进行安装。

- Please refer to the "Product Catalogue" link for detailed grounding hole locations and size at <http://www.trinasolar.com/>

请访问<http://www.trinasolar.com/>查看“产品目录”链接以了解详细的接地孔位置和尺寸。

- Grounding hardware comes in a package that includes the grounding screw, flat washer, star washer and wire

套装附带有接地硬件，其中包括接地螺丝、平垫圈、星形垫圈、链接导线。

- Electrical contact is made by penetrating the anodized coating of the aluminum frame, and tightening the mounting screw (come with the star washer) to the proper torque of 25lbf.in.

电接触点是通过穿透铝边框的阳极氧化涂层并拧紧接地螺丝（与星形垫圈一起）至25lbf.in的适当扭矩形成的。

- Grounding wire size (6 to 12 AWG solid bare copper) should be selected and installed underneath the wire binding bolt.

应选择合适尺寸的接地线（按照美国线规6至12 的实心裸铜线）并将其安装固定在连接螺栓下面。

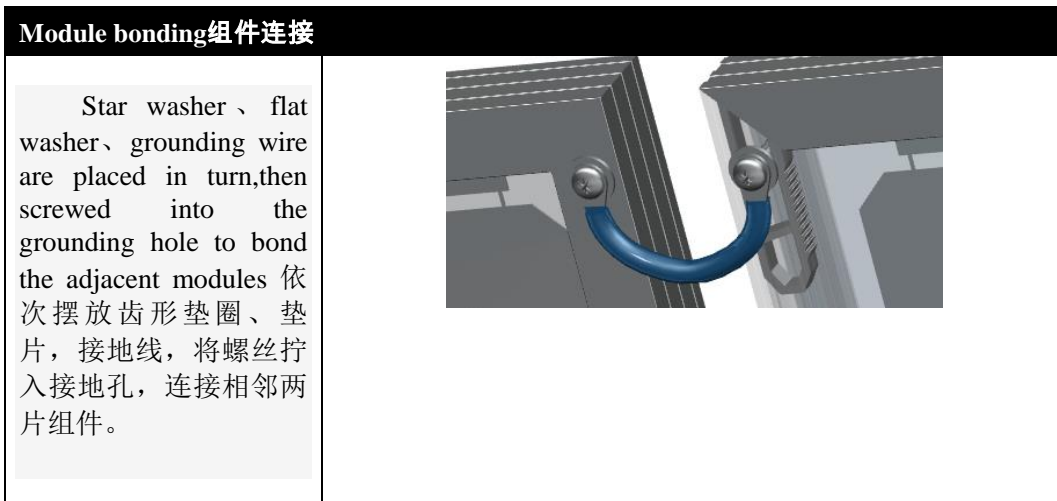
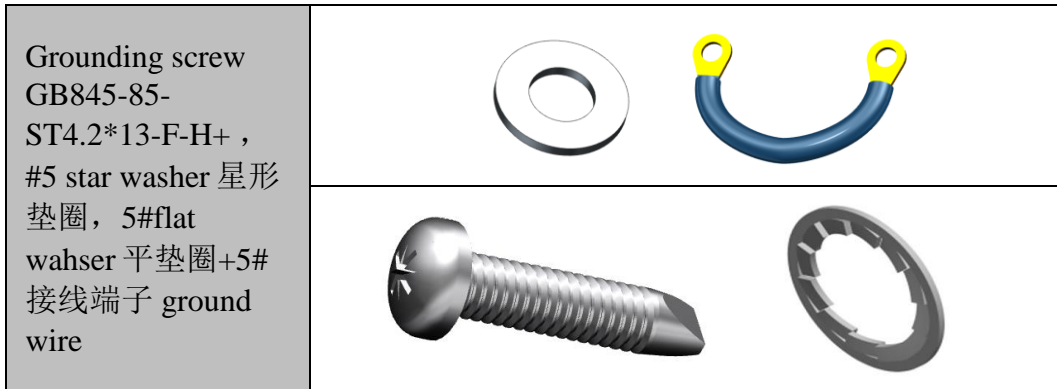

### 7.2.3 ELECTRICAL INSTALLATION 电气安装

- All wiring should be performed, by qualified installers, in accordance with the local codes and regulations.

所有接线应由合格的安装人员按照当地法规和程序进行。

- Modules can be connected in series to increase the operating voltage by plugging the positive plug of one module into the negative socket of the next. Before connecting modules always ensure that the contacts are corrosion free, clean and dry.

组件可以串联，通过将一个组件的正极插头插入下一个组件的负极插座来提高工作电压。在连接组件之前，始终确保触点无腐蚀、清洁并且干燥。

- Product can be irreparably damaged if an array string is connected in reverse polarity to another. Always verify the voltage and polarity of each individual string before making a parallel connection. If you measure a reversed polarity or a difference of more than 10V between strings then check the string

configuration before making the connection.

如果一组阵列以相反极性连接到另一个，则会对产品造成无法修复的损坏。在进行并联之前，请务必确认各列的电压和极性。如果测量发现各列之间的极性相反或电压差值大于10V，则在连接之前检查其结构配置。

- Trina Solar modules are provided with stranded copper cables with a cross sectional area of 4mm<sup>2</sup>(0.006in<sup>2</sup>) which are rated for 1500V DC, 90°C and are UV resistant. All other cables used to connect the DC system should have a similar (or better) specification. Trina Solar recommends that all cables are run in appropriate conduits and sited away from areas prone to water collection.

天合光能的太阳能组件采用适合额定参数1500V直流及温度90°C 的截面积为4mm<sup>2</sup> (0.006in<sup>2</sup>) 且防紫外线的绞合铜电缆。用于连接直流系统的所有其他电缆应具有相似（或更高）规格。天合光能建议所有电缆应布设在适当的管道中且远离易积水的地方。

- The maximum voltage of the system must be less than the maximum certified voltage 1500V typically and the maximum input voltage of the inverter and of the other electrical devices installed in the system. To ensure that this is the case, the open circuit voltage of the array string needs to be calculated at the lowest expected ambient temperature for the location. This can be done using the following formula.

系统的最高电压必须低于1500V的最高认证电压以及安装中系统中的变频器及其他电气设备的最高输入电压。为了确保这种情况，阵列的开路电压需要在该位置的最低预期环境温度下计算。可以使用以下公式进行计算：

$$\text{Max System voltage} \geq N * \text{Voc} * [1 + \text{TCvoc} * (\text{Tmin}-25)]$$

$$\text{最大系统电压} \geq N * \text{Voc} * [1 + \text{TCvoc} * (\text{Tmin}-25)]$$

Where 其中

N Number of modules in series 表示无串联组件

Voc Open circuit voltage of each module (refer to product label or data sheet)  
表示各组件的开路电压（参考产品标签或数据表）

TCvoc Thermal coefficient of open circuit voltage for the module (refer to data sheet)  
表示组件开路电压的温度系数（参见数据表）

Tmin The lowest expected ambient temperature  
表示最低环境温度

- Each module has two standards 90°C sunlight resistant output cables each terminated with plug & play connectors. The wire type and gauge of the output cables are 1500V rated PV Wire cable and are 12AWG in size. This cable is suitable for applications where wiring is exposed to the direct sunlight. We require that all wiring and electrical connections comply with the appropriate National Electrical Code.

每个组件都有两条标准的90°C遮光输出电缆且在每个端子上接有即插即用的连接器。输出电缆的类型和规格为1500V的额定PV导线电缆，其尺寸为12AWG。该电缆适用于接线直接暴露在阳光下的情况。我司要求所有接线和电气连接符合相应的《国家电气规程》要求。

- The minimum and maximum outer diameters of the cable are 5 to 7mm (0.038 to 0.076in<sup>2</sup>).

电缆的外径范围为5到7mm（0.038~0.076 in<sup>2</sup>）。

- For field connections, use at least 4mm<sup>2</sup> copper wires insulated for a minimum of 90°C and sunlight resistance with insulation designated as PV Wire.

现场接线应使用最低90°C耐温、耐光且横截面不低于为4mm<sup>2</sup>的铜线作为PV连接线。

- The minimum bending radius cables should be 43mm (1.69in).

电缆的最小弯曲半径应为43mm（1.69英寸）。

### 7.2.3.1 WIRING 接线

- To ensure proper system operation the correct cable connection polarity (Figures 1 & 2) should be observed when connecting the modules to each other or to a load, such as inverter, a battery etc. If modules were not connected correctly, the bypass diode could be destroyed. PV modules can be wired in series to increase voltage. A series connection is made when the wire from the positive terminal of one module is connected to the negative terminal of the next module. Figure 1 shows modules connected in series. PV modules can be connected in parallel to increase current (Figure 2). A parallel connection is made when the wire from the positive terminal of one module is connected to the positive terminal on the next module.

为了确保系统正常运行，在连接组件或连接负载（如变频器、电池等）时，应观察确保电缆的极性连接正确（图1和图2所示）。如果组件连接不正确，旁路二极管可能会损坏。PV组件可以串联接线以增加电压。串联连接是将接线从一个组件的正极端子连接到下一个组件的负极端子上。图1显示了组件的串联连接方式。PV组件可以并联连接以增加电流（图2所示）。并联连接是将接线从一个组件的正极端子连接到下一个组件的正极端子上。

- The number of modules in series and in parallel shall be designed reasonably according to the system configuration.

组件串联并联数量，需根据系统配置合理设计

- All instructions above have to be obeyed to maintain Trina Solar's limited warranty

必须遵守上述所有说明以满足天合光能保修条件。

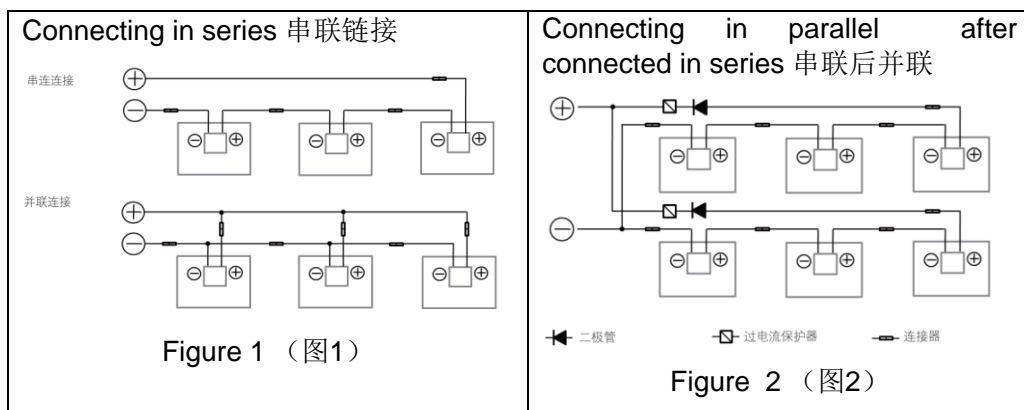

### 7.2.3.2 FUSING 熔丝

- When fuses are fitted they should be rated for the maximum DC voltage and connected in each, non-grounded pole of the array (i.e. if the system is not grounded then fuses should be connected in both the positive and negative poles).

在安装熔丝时应将其额定为最大直流电压并连接到阵列的每个非接地极上（换言之，如果系统没有接地则应将熔丝连接到正负极上）。

- The maximum rating of a fuse connected in series with an array string is typically 15A but the actual module specific rating can be found on the product label and in the product datasheet.

与阵列串联连接的熔丝的最大额定值通常为15A，但实际的组件特定额定值可在产品标签和产品数据表中获得。

- This fuse rating value also corresponds to the maximum reverse current that a module can withstand (when one string is shaded then the other parallel strings of modules will be loaded by the shaded string and current will flow) and therefore impacts the number of strings in parallel.

该熔丝的额定值也对应于组件可承受的最大反向电流值（当一个阵列被遮蔽时，该阵列会加载到其他并联的组件阵列生成电流），因此会对并列连接阵列的数量产生影响。

- Do NOT share a fuse in a Combiner Box with two or more strings in parallel connection.

禁止两串或多串并联后再接熔丝。

## 8. INVERTER SELECTION AND COMPATIBILITY 逆变器的选择及其兼容性

- When installed in systems governed by IEC regulations, Trina Solar modules normally do not need to be electronically connected to earth and therefore can be operated together with either galvanically isolated (with transformer) and transformerless inverters.

当安装在符合IEC规定的系统中时，天合光能的组件通常不需要接地，因此可以与电隔离式的逆变器（带变压器）或无变压器式的逆变器一起工作。

- Potential Induced Degradation (PID) is sometimes observed in PV modules due to a combination of high humidity, high temperature and high voltage. PID is most likely to cause degradation under the following conditions:

由于高湿度、高温和高电压等综合因素，有时在PV组件中会出现电势诱发衰减效应（PID）。PID在以下条件下最有可能导致衰减：

- Installations in the warm and humid climates  
在温暖和潮湿的气候条件下安装
- Installation close to a source of continual moisture, such as bodies of water  
在靠近水体等有持续水分来源的地方安装

- To reduce the risk of PID, we strongly suggest that modules feature Trina Solar's Anti-PID technology, which can be applied to any Trina product. Alternatively, we recommend the use of an inverter that includes a transformer as well as proper grounding of the negative DC leg of the PV array.

为降低PID带来的风险，我司强烈建议组件采用天合光能的反PID技术，这项技术可应用于天合光能的所有产品。或者采用我司的另一建议，即使用带变压器的逆变器并确保PV阵列的负直流支路正确接地。

- Choose inverters with isolation transformers in hot and wet areas (such as shores, wetlands), to ensure proper module function under positive voltage.

在炎热和潮湿的地区（如海岸、湿地）选择带有隔离变压器的逆变器以确保组件在正电压下的正常工作。

## 9. MODULE MAINTENANCE FOR PV MODULE PV 组件的维护

### 9.1 PANEL VISUAL INSPECTION AND REPLACEMENT 组件外观检查和替换

The modules in a PV array should be regularly checked for damage. Factors such as glass breakage, cable breakage, and junction box damage may lead to function and safety problems. In the case of a damaged module, replace it with the same type of module. Refer to the *Product Installation Manual* for installation and dis-assembly of module.

应定期检查光伏方阵中组件是否有坏，例如玻璃破裂、线缆破损、接线盒损坏等因素导致组件发生功能性和安全性故障，须更换相同型号组件。

A well designed solar system requires minimal maintenance; however, system performance and reliability can be improved by taking some simple steps.

设计良好的太阳能系统极少需要维护，但也可以采取一些简单的步骤来提升系统性能和可靠性。

- Maintenance should be carried out at least once a year by trained personnel, always wearing rubber gloves and boots with maximum working voltage not lower than 1500V DC.

每年至少应由经过培训的人员对其进行一次维护；在最大工作电压不低于1500V DC时，维护人员在工作期间应一直戴着橡胶手套并穿着绝缘靴

Trim any vegetation which may shade the solar array, thus impacting performance.

除去一切可能遮蔽太阳能阵列从而会影响其性能的植被。

- Check that mounting hardware is properly tightened.  
检查安装的硬件是否紧固到位。
- Check that all string fuses in each non/earthed pole are operating.  
检查每个非接地极中的所有阵列熔丝是否正常工作。

- Replacement modules must be of same type. Do NOT touch live parts of cables and connectors. Use appropriate safety equipment (insulated tools, insulating gloves, etc.) when handling modules.

组件必须用相同类型的更换。不许触碰电缆和连接器的带电部位。搬运组件时应使用适当的安全防护装置（绝缘工具、绝缘手套等）。

- Cover the front surface of modules by an opaque material when repairing. Modules when exposed to sunlight generate high voltage and are dangerous.

修复时用不透明材料覆于组件的前侧表面上。暴露在阳光下的组件会产生高电压，极其危险。

- Trina Solar PV modules are equipped with bypass diodes in the junction box. This minimizes module heating and current losses.

天合光能的光伏组件接线盒中配有旁路二极管，会使组件加热和电流的损耗最小化。

- Do NOT open the junction box to change the diodes even if they malfunction.

不许尝试打开接线盒更换二极管，即使它们发生故障。

- In a system using a battery, blocking diodes are typically placed between the battery and the PV module output to prevent battery discharge at night.

在使用电池的系统中，阻塞二极管通常放置在电池和 PV 组件输出装置之间以防止夜间电池放电。

- In the event that a module is damaged (broken glass or a scratch on back sheet) and needs to be replaced

如果组件损坏（玻璃破碎或背板上有划痕），则需要对其进行更换。

- Observe the safety precautions listed earlier in the Manual  
请注意本手册前面列出的安全注意事项。
- Wear cut resistant gloves and other personal protective equipment required for the particular installation.  
进行特殊安装时需要穿戴防切割手套和其他个人防护装备。
- Isolate the impacted array string to prevent current flow before attempting to remove the module.  
在尝试移除组件之前，一定要将受影响的阵列隔离以防止电流产生。
- Disconnect the connectors of the affected module using the related disconnect tool provided by suppliers.  
用供应商提供的相关断开工具去断开受影响组件的连接。
- Replace the damaged module with a new module of the same type.  
使用相同类型的新组件更换损坏的组件。
- Check the open circuit voltage of the array string and verify that this is within 10V of the other strings to be connected in parallel.  
检查阵列的开路电压并验证与其并联连接的其他阵列的开路电压是否在 10V 以内。
- Turn the breaker back on.  
重新合上断路器。

## 9.2 CONNECTOR AND CABLE INSPECTION 连接器和线缆检查

- Inspect all cables to verify that connections are tight; the cables are protected from direct sunlight and sited away from areas of water collection.

检查所有电缆以验证其连接是否牢固；避免电缆受阳光直射且使其远离积水区域。

- It is recommended to check the torque of terminal bolts and the general condition of wiring at least once a year. Also, check that mounting hardware is properly torqued. Loose connections will result in damage to the array.

建议至少每年检查一次端子螺栓的扭矩和接线的各方面情况。此外，检查安装的硬件是否紧固到位。连接松动会导致阵列损坏。

## 9.3 CLEANNING 清洗

The amount of electricity generated by a solar module is proportional to the amount of light falling on it. A module with shaded cells will produce less energy and therefore it is important to keep modules clean.

太阳能组件产生的电量与落在其上的光照成比例。电池被遮挡的组件产生的能量相对较少，因此保持组件的清洁十分重要。

- Clean PV modules when the irradiance is below 200W/m<sup>2</sup>; liquid with a large

temperature difference from the modules shall not be used for cleaning the modules;

应在辐照度低于200W/m<sup>2</sup>的情况下清洁光伏组件，不宜使用与组件温差较大的液体清洗组件；

- It is forbidden to clean PV modules under the weather conditions of wind more than 4 grades, heavy rain or heavy snow;

严禁在风力大于4级、大雨或大雪的气象条件下清洗光伏组件；

- When cleaning with pressurized water, the water pressure on the glass surface of the module shall not exceed 700 KPa (14619.80psf); the module is prohibited to bear the extra force;

压力水流清洗时，组件玻璃表面的水压不得超过700千帕(14619.80磅/英尺<sup>2</sup>)，组件严禁承受额外的外力；

- When cleaning PV modules, do NOT step on the modules; do NOT spray water on the backside of the module or the cables; do NOT clean the backside of the modules; keep the connectors clean and dry; prevent fire and electrical shock from occurring; do NOT use as steam cleaner;

光伏组件清洁工作中，严禁踩踏组件、严禁流水溅射至组件背面和电缆，严禁清洁组件背面，要保证连接头的清洁和干燥，防止电击和火灾危险；严禁使用蒸汽清洁器；

- Periodically trim any vegetation which may shade the solar array thus impacting performance.

应定期削减植被，避免植被遮挡光伏组件。

- When cleaning the modules, use a soft cloth together with a mild detergent and clean water. Take care to avoid severe thermal shocks which might damage the module by cleaning modules with water which has a similar temperature to the modules being cleaned.

清洁组件时，应使用软布和温和的清洁剂以及清水。注意避免出现严重的可能损坏组件的热冲击。清洁组件时应保证水与组件之间的温差不大。

- Use dry or wet soft clean cloth to clean the PV modules; non-corrosive solvents or hard objects are strictly prohibited;

应使用干燥或潮湿的柔软洁净的布料擦拭光伏组件，严禁使用腐蚀性溶剂或用硬物擦拭光伏组件；

- If there are greasy dirt and other substances on the surface of the PV module which are difficult to clean, use a friction-free neutral liquid detergent; Do NOT use any organic solvent containing acid or alkaline to clean the module.

光伏组件表面有油污等难清洁物质，使用无摩擦的中性液体清洁剂Do NOT use 含有碱、酸的有机溶剂清洁组件。

- When cleaning the back surface of the module, take care to avoid penetrating the substrate material. Modules that are mounted flat (0° tilt angle) should be cleaned more often, as they will NOT "self-clean" as effectively as modules mounted at a 10° tilt or greater.

清洁组件的背面时，注意避免清洗液渗到材料底层。应稍微频繁地清洁水平安装的组件（0°倾斜角），因为这些组件不会像以10°倾斜角或更大倾斜角安装的组件那样具有“自清洁”功能。



- If you are unsure whether the array or section there of needs to be cleaned, first select an array string that is particularly soiled, then  
如果不确定是否需要清除阵列或截面，则首先选择一列特别脏的阵列开始。
- Measure & record the inverter feed in current from that string  
测量并记录来自变频器对该列电流的反馈
  - Clean all modules in the string  
清洗该列的所有组件
  - Measure the inverter feed in current again and calculate the % improvement from cleaning  
重新测量变频器的反馈电流并计算清洁后的改进百分比。
- If the improvement is less than 5% then it is normally not worth spending the expense on cleaning. The above verification should only be carried out when the insolation is effectively constant (clear sky, strong sunshine, no clouds)  
如果改进百分比小于5%，则通常也不值得花费功夫清洁。上述验证应当仅在日照率恒定（晴天、日照强、无云）的情况下进行。
- The back surface of the module normally does not need to be cleaned but, in the event this is deemed necessary, avoid the use of any sharp projects that might damage the penetrating the substrate material.  
组件的后表面通常不需要清洁；但在认为确实有必要对其进行清洗时，应避免使用可能引起损坏或穿透基底材料的一切尖锐物体。

### 9.3.1 REQUIREMENTS FOR WATER QUALITY 水质要求

- PH: 5 ~7;
- Chloride and Salinity 氯化物或盐分含量: 0 - 3,000 mg/L
- Turbidity 浑浊度: 0-30 NTU
- Conductivity 电导率: 1500~3000  $\mu\text{s}/\text{cm}$
- Total dissolved solids (TDS)总溶解固体:  $\leq 1000$  mg/L
- Water Hardness—calcium and magnesium ions 水硬度: 0-40 mg/L
- Non-alkaline water must be used; demineralized water shall be used if the condition permits.  
必须采用非碱性水，具备条件时应使用软化水。

### 9.3.2 MODULE INSPECTION AFTER CLEANING 清洗后组件检查

- Ensure that the module under visual inspection is clean, bright and free of stains;  
目视组件整体外观清洁、明亮，无污渍；
- Spot check to verify whether there is soot deposit on the module surface;  
抽样检查组件表面是否有积灰存在；
- Check to see that there are no visible scratches on the surface of the module;  
组件表面无明显的刮伤痕迹；
- Check to see that no man-made cracks are on the module surface;

组件表面无人为造成的破裂现象；

- Check to see that whether the module support structure is leaning or bent after cleaning;

清洗后组件支架有无倾斜、弯曲现象；

- Check to see that whether the wiring terminals of the module are detached;

组件接线端子是否有脱落的现象等；

- After cleaning PV modules, fill out the PV module cleaning record.

光伏组件清洗完后，完成光伏组件清洗文字记录。

### 9.3.3 TROUBLESHOOTING 故障排查

- If your installation does not work properly, please inform your installer immediately.

如果安装后无法正常工作，请立即通知安装商。

## 10. REPORTING TECHNICAL ISSUES or CLAIMS 技术问题或索赔

- Contact your installer

请联系安装商

- Contact Trina Solar after sales service team at <http://customerservice.trinasolar.com/>

请登录<http://customerservice.trinasolar.com> 联系天合光能的售后服务团队

- Submit the Customer Feedback form at: <http://www.trinasolar.com/> and one of our technical service representatives will contact you within 5 business days. A username and password is required to send feedback from the customer service link.

请通过<http://www.trinasolar.com/>提交《客户反馈信息表》。我司的技术服务代表会在5个工作日内与您联系。所需用户名和密码会通过客户服务链接发送。

- For module specifications or datasheets, please download from: <http://www.trinasolar.com/>

请在<http://www.trinasolar.com/>上下载关于组件的规格或数据表。