

AGILE W/ DEG 19 MODULES - TOP VIEW

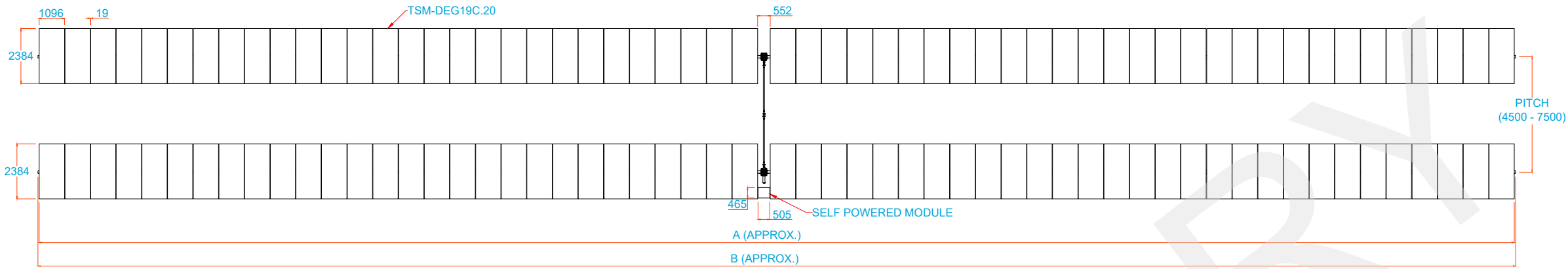

FRONT VIEW

AGILE OUTER

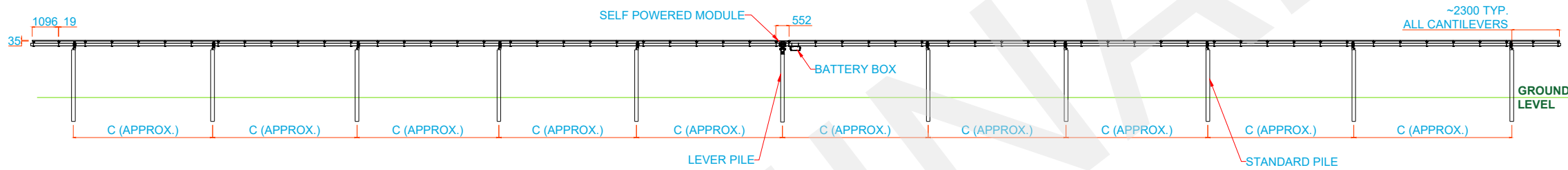

FRONT VIEW

AGILE BORDER AND INNER

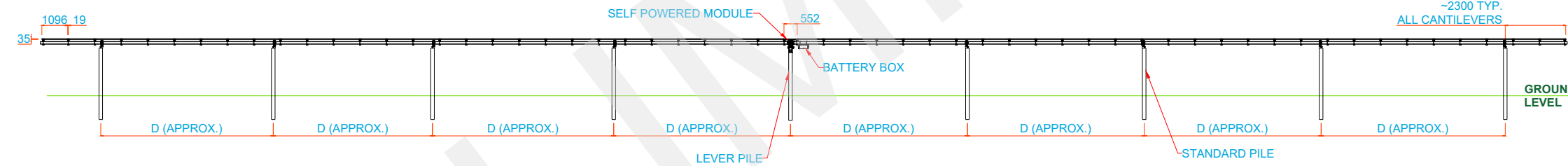

PROFILE VIEW

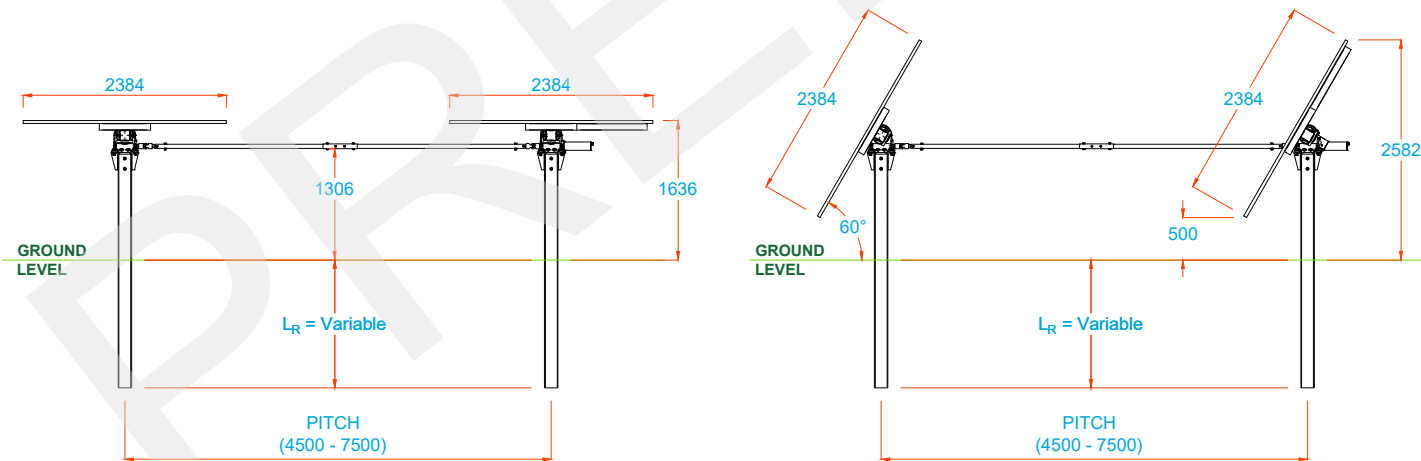

AGILE TRACKER –
TSM-DEG19C.20 MODULE (2384X1096X35 mm)

TRACKER	MODULES/ STRING	STRINGS/ TRACKER ROW	DIM. A (mm)	DIM. B (mm)	DIM. C (mm)	DIM. D (mm)
1Vx57	38	1.5	64069	64189	5950	7435
1Vx55+ 1Vx56*	37	1.5	62954	63074	5835	7295
1Vx54	36	1.5	60724	60844	5610	7015
1Vx52+ 1Vx53*	35	1.5	59609	59729	5500	6875
1Vx51	34	1.5	57379	57499	5230	6600

NOTES:

- SHEET 1 VIEWS SHOW 1Vx57 TRACKER, USE TABLE TO FIND DIMENSIONS FOR OTHER CONFIGURATIONS
- DIMENSIONS SHOWN IN TABLE ARE APPROXIMATE AND FOR REPRESENTATIVE PURPOSES ONLY
- LAYOUT, MEMBER SIZES, SPACINGS, ETC. SUBJECT TO CHANGE DURING FINAL DESIGN PHASE
- * TRACKERS WITH EXTRA MODULE SHOWN ON SHEET 2 (1Vx55+1Vx56 TRACKER SHOWN IN VIEWS)

Nº	Name	Date	Reason for modification
1	AKM	6/24/21	UPDATE TRACKER CLASSIFICATION
2			
3			
4			

GENERAL NOTES

1. ONLY VALID FOR QUOTATION PURPOSE

REFERENCE DOCUMENTS

1. TECHNICAL SPECIFICATION:
2. MODULE DATASHEET: Datasheet_Bifacial Vertex DEG19C.20(II)_2021_A.pdf

NOTES

AGILE TRACKER

CONFIGURATION:

- TILT: +/- 60°
- DRIVE UNIT: SLEWING DRIVE

MODULE:

- MODEL: TSM-DEG19C.20
- DIMENSIONS: 2384 x 1096 x 35 mm

PILES:

- OUTER TRACKERS:
 - TYP. QTY. 1 LEVER PILE, QTY. 10 STANDARD PILE
 - TYP. LEVER PILE SECTIONS: W6x15, W6x20, W8x13
 - TYP. STANDARD PILE SECTIONS: W6x9, W8x10
- INNER/BORDER TRACKERS:
 - TYP. QTY. 1 LEVER PILE, QTY. 8 STANDARD PILE
 - TYP. LEVER PILE SECTIONS: W6x15, W6x20, W8x13
 - TYP. STANDARD PILE SECTIONS INNER: W6x7, C200x80x32x3
 - TYP. STANDARD PILE SECTIONS BORDER: W6x7, W6x9, W8x10
- QTY, SECTIONS, AND SPACINGS SUBJECT TO CHANGE DUE TO SITE SPECIFIC LOADING AND SPECIFICATIONS

MAXIMUM GROUND SLOPES FOR TRACKER INSTALLATION:

- 20 % NORTH - SOUTH DIRECTION
- 10 % EAST - WEST DIRECTION

Units in mm

Prepared	Date	Name	Revision
29/04/21	AKM		
Revised			
Approved			
Scale:	AGILE W/ DEG19 MODULES		Sheet 1/2
N/S	VIEWS -PRELIMINARY-		Revision 01
Reference:			

AGILE W/ DEG 19 MODULES - TOP VIEW

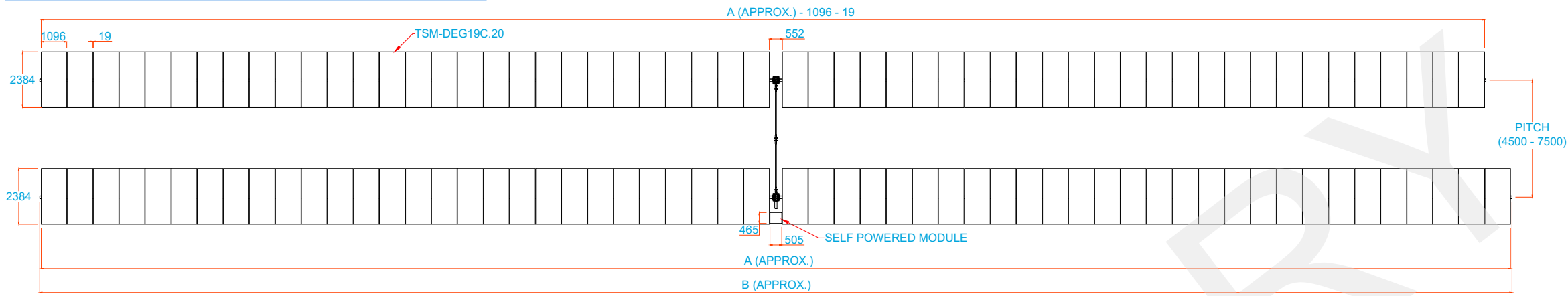

FRONT VIEW

AGILE OUTER

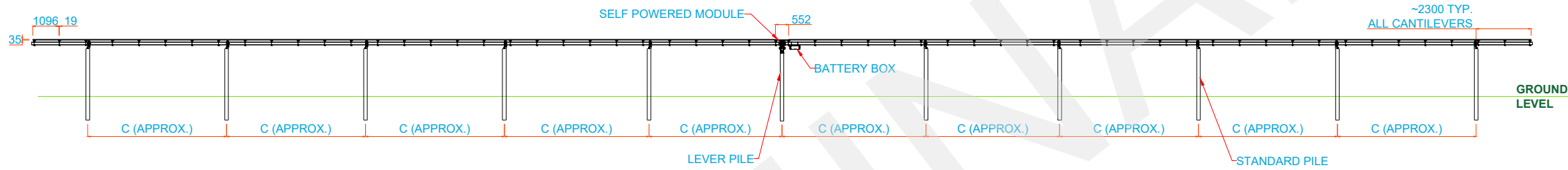

FRONT VIEW

AGILE BORDER AND INNER

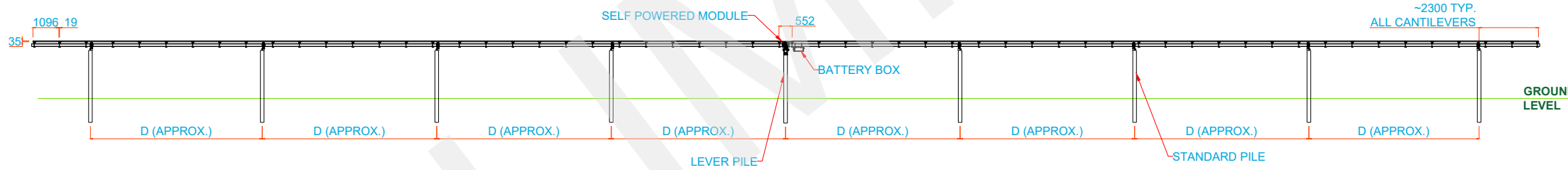

PROFILE VIEW

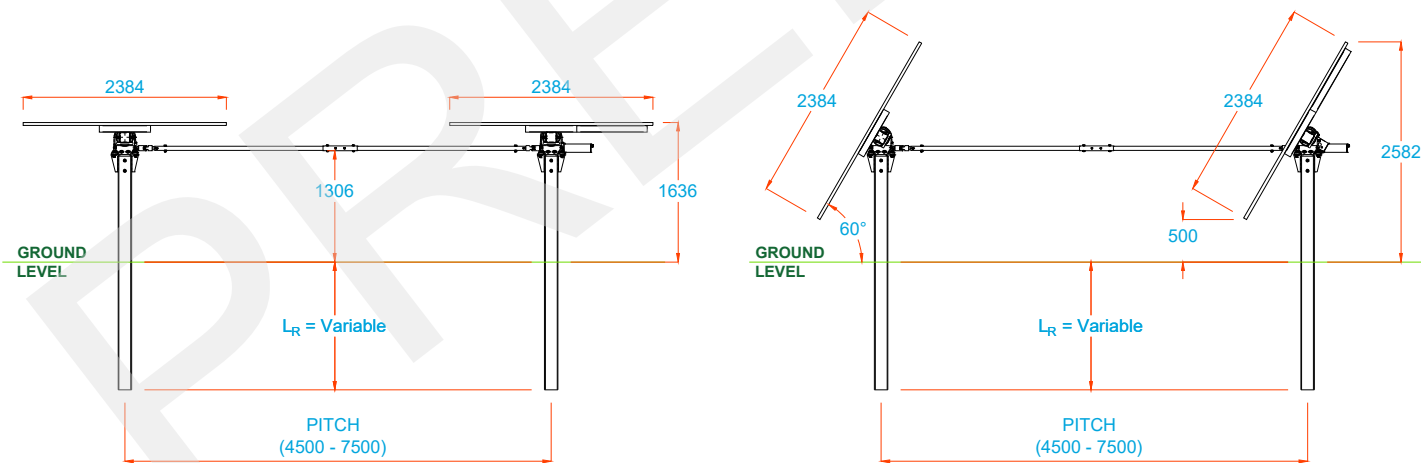

AGILE TRACKER –
TSM-DEG19C.20 MODULE (2384X1096X35 mm)

TRACKER	MODULES/ STRING	STRINGS/ TRACKER ROW	DIM. A (mm)	DIM. B (mm)	DIM. C (mm)	DIM. D (mm)
1Vx57	38	1.5	64069	64189	5950	7435
1Vx55+ 1Vx56*	37	1.5	62954	63074	5835	7295
1Vx54	36	1.5	60724	60844	5610	7015
1Vx52+ 1Vx53*	35	1.5	59609	59729	5500	6875
1Vx51	34	1.5	57379	57499	5230	6600

NOTES:
 - SHEET 1 VIEWS SHOW 1Vx57 TRACKER, USE TABLE TO FIND DIMENSIONS FOR OTHER CONFIGURATIONS
 - DIMENSIONS SHOWN IN TABLE ARE APPROXIMATE AND FOR REPRESENTATIVE PURPOSES ONLY
 - LAYOUT, MEMBER SIZES, SPACINGS, ETC. SUBJECT TO CHANGE DURING FINAL DESIGN PHASE
 * TRACKERS WITH EXTRA MODULE SHOWN ON SHEET 2 (1Vx55+1Vx56 TRACKER SHOWN IN VIEWS)

Nº	Name	Date	Reason for modification
1	AKM	6/24/21	UPDATE TRACKER CLASSIFICATION
2			
3			
4			

GENERAL NOTES

- 1. ONLY VALID FOR QUOTATION PURPOSE

REFERENCE DOCUMENTS

- 1. TECHNICAL SPECIFICATION:
- 2. MODULE DATASHEET: Datasheet_Bifacial Vertex DEG19C.20(II)_2021_A.pdf

NOTES

AGILE TRACKER

CONFIGURATION:

- TILT: +/- 60°
- DRIVE UNIT: SLEWING DRIVE

MODULE:

- MODEL: TSM-DEG19C.20
- DIMENSIONS: 2384 x 1096 x 35 mm

PILES:

- OUTER TRACKERS:
 - TYP. QTY. 1 LEVER PILE, QTY. 10 STANDARD PILE
 - TYP. LEVER PILE SECTIONS: W6x15, W6x20, W8x13
 - TYP. STANDARD PILE SECTIONS: W6x9, W8x10
- INNER/BORDER TRACKERS:
 - TYP. QTY. 1 LEVER PILE, QTY. 8 STANDARD PILE
 - TYP. LEVER PILE SECTIONS: W6x15, W6x20, W8x13
 - TYP. STANDARD PILE SECTIONS INNER: W6x7, C200x80x32x3
 - TYP. STANDARD PILE SECTIONS BORDER: W6x7, W6x9, W8x10
- QTY, SECTIONS, AND SPACINGS SUBJECT TO CHANGE DUE TO SITE SPECIFIC LOADING AND SPECIFICATIONS

MAXIMUM GROUND SLOPES FOR TRACKER INSTALLATION:

- 20 % NORTH - SOUTH DIRECTION
- 10 % EAST - WEST DIRECTION

Units in mm

Prepared	Date	Name	Revision
29/04/21	29/04/21	AKM	
Revised			
Approved			
Scale:	AGILE W/ DEG19 MODULES		Sheet 2/2
N/S	VIEWS -PRELIMINARY-		Revision 01
Reference:			